

THE GUARANTEED AUDIOTRON

(TRADE MARK)

THE ONLY ORIGINAL AND GENUINE TUBULAR

DETECTOR AMPLIFIER OSCILLATOR

The AudioTron is the very latest development in detectors of extreme sensitiveness. Comparative tests within the last six months—not ancient tests which are valueless in view of the rapid developments in radio telegraphy—prove that the AudioTron is at least 100% more sensitive than any other detector—without exception.



The AudioTron is of the pure electron discharge type. It differs from the audion, and other gaseous detectors, in that it depends for its sensitiveness and operation on the emission of negative electrons from an incandescent tungsten filament and not on the ionization of a gaseous medium. This electron stream from the hot cathode to the cold plate anode, which acts as a carrier for the B battery current, is varied by and in accordance with the impressed potential on the spiral grid, thus producing the amplified or relayed signals in the receiver. The plate is in intimate contact with the glass tube, thus assuring a cold anode at all times with resulting maximum efficiency and sensitiveness.

The grid and plate both completely surround the stream line filament, taking maximum advantage of the electron discharge from the filament, which is at the axis of the cylindrical grid and plate, resulting in uniform spacing at all points.

The grid of copper and the plate of aluminum are electropositive to each other and to the wire drawn tungsten filament, thus taking fullest advantage of this feature in the rectifying action.

The life of the AudioTron is exceptionally long, due to the absence of any loops in the filaments. Lead-in wires at opposite ends of the tube entirely eliminate destruction due to Edison effects.

The use of large grid and plate surfaces allows the use of two to three times the customary filament current with the corresponding increase in electron discharge and resulting in greater efficiency.

FOR SALE BY

Herman Gisseler.

Monticello 2624

2328 Fletcher St.

The AudioTron is the most sensitive form of detector, amplifier or oscillator. The one type tube is suitable for all three uses. The AudioTron has been used and tested for nearly a year on the Pacific Coast in amateur and commercial stations with wonderful results. Readable signals from a distance of 8,000 miles have been received with average sized aerials.

While the AudioTron detector is more sensitive than most two or three step amplifiers, it can and has been used as a two step amplifier for extreme distances. The AudioTron's extreme sensitiveness will never require the use of a three step amplifier.

As an oscillator the AudioTron is incomparable. Using amplified Armstrong circuits, signals from European stations have been read on the Pacific Coast (over 8,000 miles) even in the day time with average sized aerials.

The AudioTron tube is sold individually or built in compact AudioTron receiving, amplifying or oscillating sets. For best results we recommend the purchase of complete sets.

THE AUDIOTRON TUBE (DOUBLE FILAMENT) \$5.²⁵

Postage prepaid in the U. S. A. and Canada

All bulbs are carefully tested before shipment, are guaranteed sensitive and to arrive in good condition. When ordering specify whether AudioTron is to be used as a detector of spark or damped stations or as an oscillator for undamped wave reception. Damped wave detectors are also amplifiers. Combination tubes can be furnished at an advance of fifty cents.

BEWARE OF SUBSTITUTES

Patent has been applied for on the AudioTron and every genuine AudioTron has the name stamped on it. Be sure the tube you purchase bears this protected trade-mark. You are then assured of satisfaction.

READ WHAT SOME USERS OF AUDIOTRON WRITE US:

New York, 11/3/15.

"I don't mind telling you that the AudioTron is the best bulb I have ever used. I tried it out right away and found it much more sensitive than a — bulb, which I thought was pretty good."

New York, 11/21/15.

"Have just received and tested the AudioTron and want to tell you of the splendid results. It is much ahead of other detectors, especially as an oscillator. Germany and Honolulu come in very loud. I copied OUI (Hanover) with but one bulb and the spark systems came in from remarkable distances."

Salt Lake City, 11/29/15.

"The bulb sent me has been thoroughly tried and found not wanting in any detail. I am enclosing check for 5 more bulbs, which I wish you would ship as soon as possible."

New Castle, Pa., 12/14/15.

"The bulb you shipped is very sensitive and much better than any others we have ever handled. Enclosed find order for three more."

Seattle, Wn., 11/15/15.

"Your AudioTron has been tested and is the best bulb I have ever used regardless of make or price. The strength of signal from spark stations was from 50% to 150% stronger than on the other bulbs. As an amplifier or as an oscillator it is far ahead of everything else. The stability and strength of oscillation is greater and it operates with a minimum of secondary inductance much lower than other bulbs. Using only one bulb loud day signals were received from WSL, WGG, NAA, NAT, NBA, KHX and many nearer stations. Night signals include POZ and OUI."

Scranton, Pa., 11/19/15.

"I cannot say too much in favor of the AudioTron since the results which it gave were far better than any I have ever been able to secure by the use of an — bulb. As an example of its sensitiveness and oscillating powers, I will say that by using the bulb alone I can receive OUI (Eilvese) very clearly in daylight. My aerial is only 200' long. I can hear a spark station KET (Bolinas, Calif.) between 5 o'clock and 7:30 p. m."

Denver, Colo., 11/3/15.

"Your AudioTron beats anything I have ever used. Can hear distant stations I could not get with other bulbs. Can hear NAA with the receivers three feet away, while NPL comes in with a roar. Also get NAA when he sends at noon time and can hear and read Frisco Federal working with Los Angeles."

STRAUS-FRANK COMPANY
HOUSTON, TEXAS

Cunningham
RADIO TUBES

ENGINEERING
BULLETINS

R. J. Cunningham Inc.

NEW YORK - CHICAGO - SAN FRANCISCO
ATLANTA - DALLAS

March, 1931

STRAUS-FRANK COMPANY
HOUSTON, TEXAS

TABLE OF CONTENTS

	PAGE
Average Characteristics Table.....	5
CX-112A	17
CX-220	9
C-299	7
CX-299	7
CX-301A	15
CX-322	27
C-324	32
CX-326	39
C-327	44
CX-330	50
CX-331	54
CX-332	56
CX-345	69
CX-350	76
CX-371A	18
CX-374	81
C-376	82
CX-380	84
CX-381	88
C-386	82
Memorandum Sheets.....	93 to 98
Obsolete Tubes	Back of Book

CUNNINGHAM AVERAGE TUBE CHARACTERISTICS

TYPE	Fila. Voltage	Fila. Current (Amperes)	Plate Voltage	Grid Voltage	Amplifica. Fact.	Plate Resist. (Ohms)	Mutual Conduct. (Micromhos)	Plate Current (m. a.)	Load Resist. (Ohms)	Undist. Power Output (M.W.)	Screen Grid V.
C-11, CX-12	1.1	.25	90	4.5	6.6	15,500	425	2.5	15,500	7	
			135	10.5	6.6	15,000	440	3.0	18,000	35	
CX-112A	5.0	.25	90	4.5	8.5	5,600	1,500	5.2	5,600	30	
			135	9.0	8.5	5,300	1,600	6.2	8,700	115	
			180	13.5	8.5	5,000	1,700	7.6	10,800	260	
CX-220	3.3	.132	90	16.5	3.3	8,000	415	3.0	9,600	45	
			135	22.5	3.3	6,300	525	6.5	6,500	110	
C-299, CX-299	3.3	.063	90	4.5	6.6	15,500	425	25	15,500	7	
CX-300A	5.0	.25	45	0	20.0	30,300	666				
CX-301A	5.0	.25	90	4.5	8.0	11,000	725	2.5	11,000	15	
			135	9.0	8.0	10,000	800	3.0	20,000	55	
CX-310	7.5	1.25	250	22.0	8.0	6,000	1,330	10.0	13,000	400	
			350	31.0	8.0	5,150	1,550	16.0	11,000	900	
			425	39.0	8.0	5,000	1,600	18.0	10,000	1,600	
CX-322	3.3	.132	135	1.5	300	850,000	350	1.5			45
			135	1.5	290	600,000	480	3.3			67.5
C-324	2.5	1.75	180	1.5	420	400,000	1,050	4			75
			180	3.0	400	400,000	1,000	4			90
CX-326	1.5	1.05	90	6.0	8.2	8,600	955	3.8	9,800	30	
			135	9.0	8.2	7,200	1,135	6.3	8,800	80	
			180	13.5	8.2	7,000	1,170	7.4	10,500	180	
C-327	2.5	1.75	90	6.0	9.0	11,000	820	2.7	14,000	30	
			135	9.0	9.0	9,000	1,000	4.5	13,000	80	
			180	13.5	9.0	9,000	1,000	5.0	18,700	165	
CX-330	2.0	.060	90	4.5	9.3	1,300	700	1.8			
CX-331	2.0	.130	135	22.5	3.8	4,950	760	6.8	9,000	150	
CX-332	2.0	.060	135	3.0	580	1,150,000	505	1.4			67.5
CX-340	5.0	.25	135	1.5	30.0	150,000	200	0.2	250,000		
			180	3.0	30.0	150,000	200	0.2	250,000		
CX-345	2.5	1.5	180	34.5	3.5	1,900	1,850	27	3,500	780	
			250	50.0	3.5	1,750	2,000	34	3,900	1,600	
CX-350	7.5	1.25	250	45	3.8	2,100	1,800	28	4,300	1,000	
			350	63	3.8	1,900	2,000	45	4,100	2,400	
			400	70	3.8	1,800	2,100	55	3,670	3,400	
			450	84	3.8	1,800	2,100	55	4,350	4,600	
CX-371A	5.0	.25	90	16.5	3.0	2,250	1,330	12	3,200	125	
			135	27.0	3.0	1,960	1,520	17.5	3,500	370	
			180	40.5	3.0	1,850	1,620	20	5,350	700	
CX-380	5.0	2.0	A.C. Voltage per plate (Volts R.M.S.) 350 D.C. Output Current (maximum M.A.) 125 or A.C. Voltage per plate (Volts R.M.S.) 400 D.C. Output Current (maximum M.A.) 110								
			A.C. Plate Voltage (maximum volts R.M.S.) 700 D.C. Output Current (maximum M.A.) 85								
CX-381	7.5	1.25	A.C. Plate Voltage (maximum volts R.M.S.) 700 D.C. Output Current (maximum M.A.) 85								
CX-374	Rated Voltage (volts D.C.) 90 Starting Voltage (volts D.C.) 125 D.C. Current Range (M.A.) 10-50										
C-376	Operating Current (amperes) 1.7 Voltage Range (volts) 40-60										
C-386	Operating Current (amperes) 2.05 Voltage Range (volts) 40-60										

Cunningham RADIO TUBES

C-299, CX-299 and CX-220 3.3 VOLT FILAMENT TUBES

The C-299, CX-299 and CX-220 are a group of tubes designed for operation on dry cells. These tubes have thoriated tungsten filaments rated at 3.3 volts, 0.63 amperes and although intended for operation on three No. 6 dry cells, may be used with two lead cells or three Edison cells if necessary.

C-299 and CX-299 DRY CELL GENERAL PURPOSE TUBES

The C-299 and CX-299 are general purpose tubes designed for use as detectors or amplifiers. These tubes are identically the same except for the bases. The CX-299 has a small standard base and the C-299 has a special type base.



With any method of battery supply used, a filament rheostat should be provided to maintain constant voltage across the filament, as the life is greatly shortened by excessive voltage. When one tube is used the rheostat should be about 60 ohms, and when three tubes are operated in parallel

from three dry cells in series, the rheostat should be about 20 ohms.

Circuit Recommendations

AS A DETECTOR

When these tubes are used as detectors with grid leak and condenser, the plate voltage should preferably be not more than 45 volts. The grid condenser should be about .00025 mf. and the grid leak should have a resistance of 2-9 megohms, the latter value giving greater sensitivity on very weak signals but with somewhat inferior fidelity. The grid return should be connected to the positive side of the filament.

AS AN AMPLIFIER

When these tubes are used as amplifiers a grid bias should be

used whenever the plate voltage is over 45 volts. The following values of grid bias for various plate voltages are recommended:

Plate Voltage	Grid Bias
67.5	-3.0 volts
90.0	-4.5 volts

RATING

Filament Voltage	3.0-3.3 volts
Filament Current	0.060-0.063 amperes
Plate Voltage (maximum)	90 volts

AVERAGE CHARACTERISTICS

Plate Voltage	90 volts
Grid Bias Voltage	-4.5 volts
Amplification Factor	6.6
Mutual Conductance	15500 micromhos
Plate Resistance	425 ohms
Plate Current	2.5 milliamperes
Undistorted Power Output	7 milliwatts
Grid-Plate Capacitance	3.3 mmf.

DIMENSIONS

	C-299	CX-299
Maximum Overall Length	3½"	4⅛"
Maximum Overall Diameter	1¼"	1⅜"
Base	Small C	Small CX

AVERAGE CHARACTERISTIC CURVES

(Pages 11 and 12)

Filament and Emission Characteristics—Fig. 1 shows the change of filament current with various filament voltages.

Grid Characteristics—Fig. 2 shows the relation between grid current and grid voltage.

Plate Characteristics—Fig. 3 shows a family of plate voltage-plate current curves at various grid bias voltages.

Mutual Characteristics—Fig. 5 shows a family of grid voltage-plate current curves for various plate voltages.

Dynamic Characteristics—Fig. 4 shows the effect of grid voltage upon the amplification factor, mutual conductance and plate resistance.



CX-220

DRY CELL POWER AMPLIFIER

The CX-220 is a special purpose tube designed for operation as a power amplifier on dry cells. It is intended for use only in the last stage of an A.F. amplifier. The filament is of the thoriated tungsten type and is rated at 3.3 volts and 132 milliamperes.

Circuit Recommendations

A rheostat of at least 15 ohms should be used to maintain a constant voltage across the filament as its life may be greatly shortened by excessive voltage.

The recommended maximum plate voltage for this tube is 135 volts with a grid bias of 22.5 volts. A slight reduction in plate voltage will not cause undue distortion but the output will be decreased somewhat. It is important that the grid-bias battery voltage be maintained at the recommended value or the life of the tube may be shortened due to excessive plate current caused by a decreased grid-bias.

It is not necessary to use an output transformer with this tube and a cushion or spring mounting need not be provided when it feeds directly into a loud speaker.

RATING

Filament Voltage	3.0-3.3 volts
Filament Current	0.125-0.132 amperes
Plate Voltage (maximum)	135 volts

AVERAGE CHARACTERISTICS

Plate Voltage	90	135 volts
Grid Bias Voltage	-16.5	-22.5 volts
Amplification Factor	3.3	3.3
Mutual Conductance	415	525 micromhos
Plate Resistance	8000	6300 ohms
Plate Current	3	6.5 ohms
Undistorted Power Output	45	110 milliwatts

DIMENSIONS

Maximum Overall Length	4 1/8"
Maximum Overall Diameter	1 3/16"
Base	Small CX

AVERAGE CHARACTERISTIC CURVES

(Pages 13 and 14)

Filament Characteristic—Fig. 6 shows the change of filament current with various filament voltages.

Plate Characteristics—Fig. 8 shows the relation between the plate current and plate voltage at various bias voltages.

Mutual Characteristics—Fig. 7 shows a family of grid voltage-plate current curves at various plate voltages.

Dynamic Characteristics—Fig. 9 shows the effect of grid voltage upon the amplification factor, mutual conductance and plate resistance.

Output Characteristic—Fig. 10 shows the undistorted power output obtainable at various load resistances.

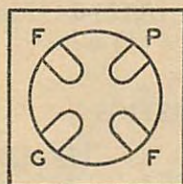
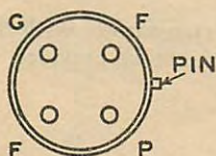

C-299

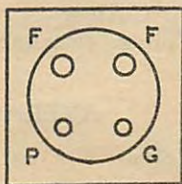

CX-299
and
CX-220

BASE AND SOCKET CONNECTIONS

C-299 AND CX-299 AVERAGE CHARACTERISTICS

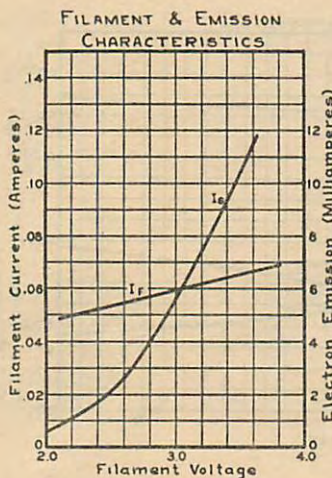

Fig. 1

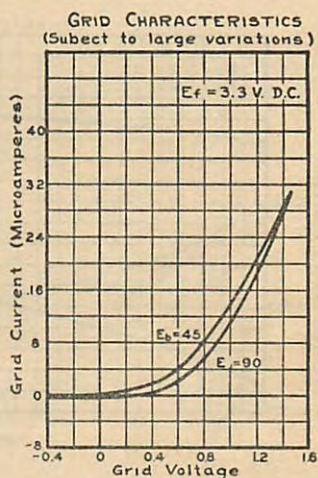

Fig. 2

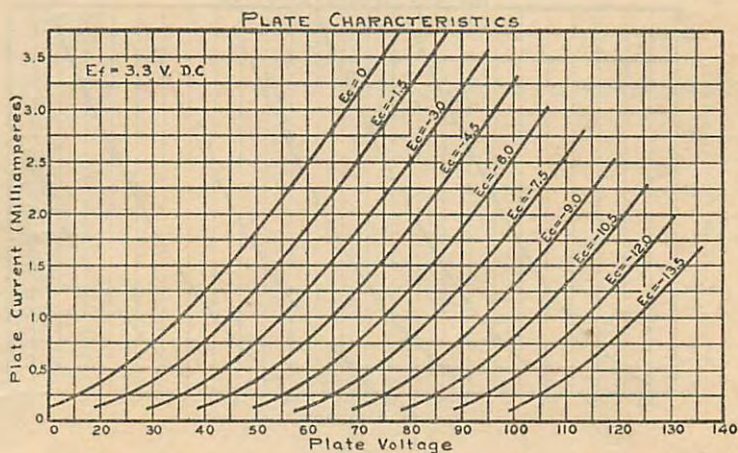

Fig. 3

C-299 AND CX-299 AVERAGE CHARACTERISTICS

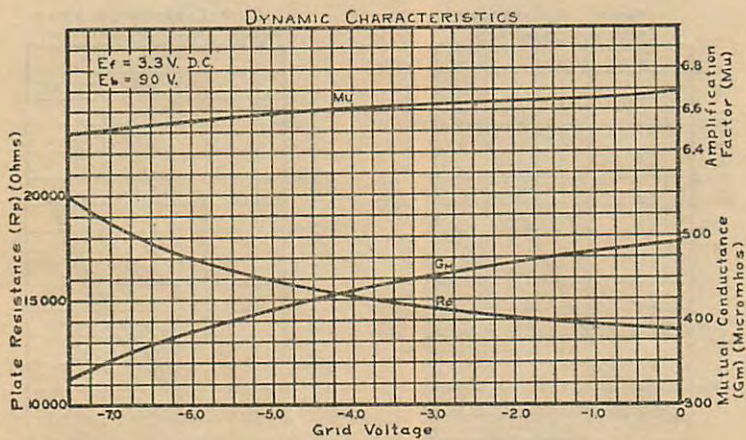

Fig. 4

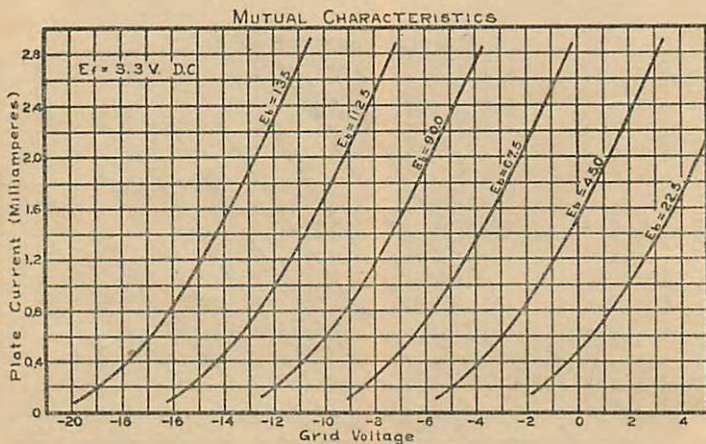

Fig. 5

CX-220

AVERAGE CHARACTERISTICS

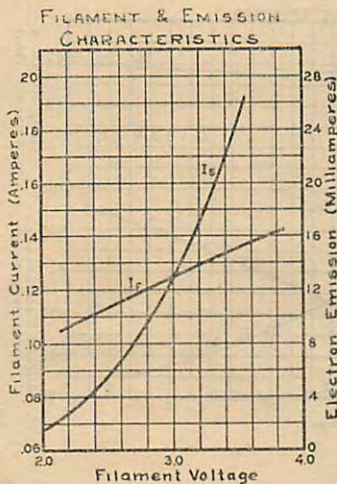

Fig. 6

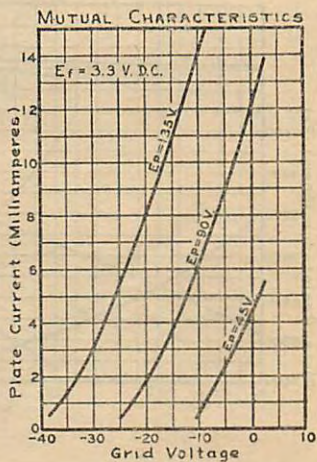

Fig. 7

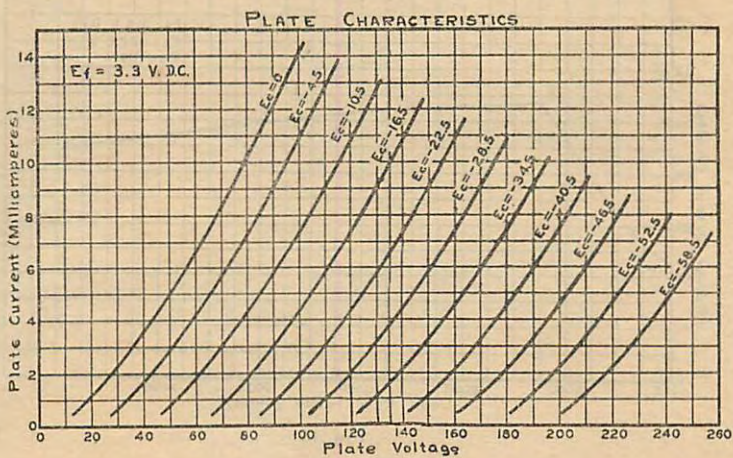

Fig. 8

CX-220 AVERAGE CHARACTERISTICS

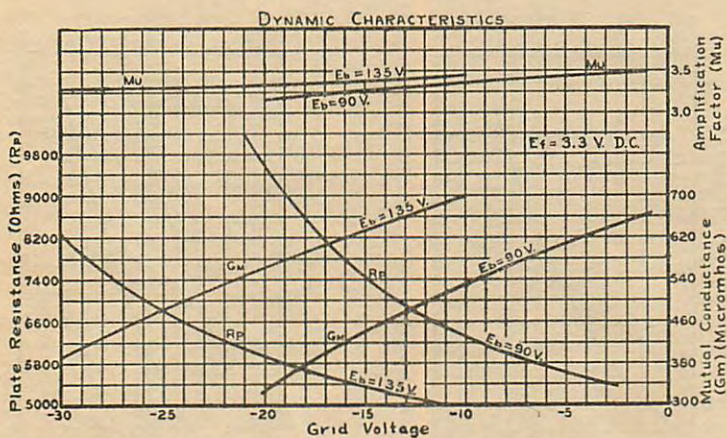

Fig. 9

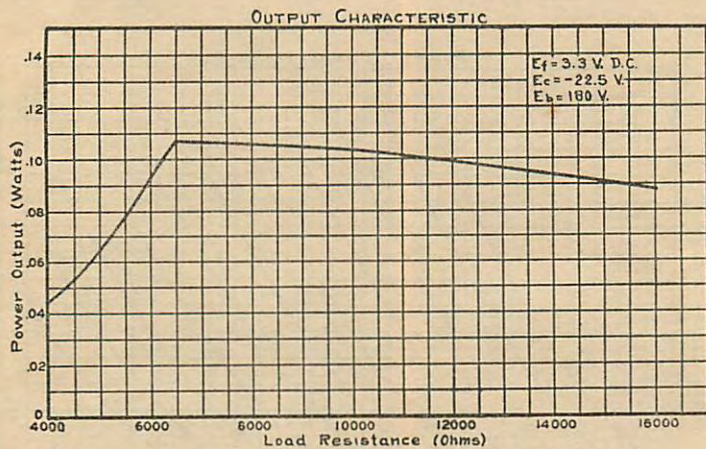

Fig. 10

Cunningham RADIO TUBES

CX-301A, CX-112A and CX-371A FIVE VOLT FILAMENT TUBES

This group of tubes includes all those having filaments designed to operate at 5.0 volts with a current drain of .25 amperes. Of these, the CX-301A and CX-112A are general purpose tubes while the CX-371A is a power amplifier tube.



CX-301A GENERAL PURPOSE TUBE

The CX-301A is a general purpose tube designed for use as a detector or an amplifier. This tube employs a thoriated tungsten filament rated at 5 volts, .25 amperes, and is designed for operation with a 6 volt storage battery.

Circuit Recommendations

AS A DETECTOR

When the CX-301A is used as a detector with grid leak and condenser, the plate voltage should preferably be not more than 45 volts. The grid condenser should have about 0.00025 mfd. capacity and the grid leak should have a resistance of 2 to 9 megohms, the latter giving greater sensitivity on very weak signals but with somewhat inferior fidelity.

AS AN AMPLIFIER

The CX-301A, when used as an amplifier, should have the following recommended grid biases applied whenever the plate voltage is over 45 volts.

<i>Plate Voltage</i>	<i>Negative Grid Bias</i>
67.5	3.0
90.0	4.5
135.0	9.0

In radio-frequency circuits there is little advantage in using more than 90 volts on the plate and when used for loud-speaker operation, the plate voltage should be 135 volts with suitable bias.

RATING

Filament Voltage	5.0 volts
Filament Current25 amperes
Plate Voltage (maximum)	135 volts

AVERAGE CHARACTERISTICS

Plate Voltage	90	135 volts
Grid Bias Voltage	-4.5	-9.0 volts
Amplification Factor	8.0	8.0
Mutual Conductance	725	800 micromhos
Plate Resistance	11000	10000 ohms
Plate Current	2.5	3.0 milliamperes
Undistorted Power Output	15	55 milliwatts
Grid-Plate Capacitance	8.1 mmf.	
Grid Filament Capacitance	3.1 mmf.	
Plate-Filament Capacitance	2.2 mmf.	

DIMENSIONS

Maximum Overall Length	4 $\frac{11}{16}$ "
Maximum Overall Diameter	1 $\frac{13}{16}$ "
Base	Large CX

AVERAGE CHARACTERISTIC CURVES

(Pages 21 and 22)

Filament and Emission Characteristics—Fig. 1 shows the change of filament current and electron emission with various filament voltages.

Grid Characteristics—Fig. 2 shows the relation between grid current and voltage.

Plate Characteristics—Fig. 3 shows a family of plate voltage-plate current curves at various grid bias voltages.

Mutual Characteristics—Fig. 5 shows a family of grid voltage-plate current curves for various plate voltages.

Dynamic Characteristics—Fig. 4 shows the effect of grid voltage upon the amplification factor, mutual conductance and plate resistance.



CX-112A GENERAL PURPOSE TUBE

The CX-112A is a general purpose tube for use as a detector or amplifier and especially adapted for use as a power amplifier in the last A.F. stage. This tube employs an oxide coated filament rated at 5 volts, 0.25 amperes, and is designed for operation with a 6 volt storage battery.

Circuit Recommendations

AS A DETECTOR

When grid bias detection is used, plate voltages up to 180 volts may be applied. The grid bias should be such that the plate current is about .1 milliampere when no signal is being received.

The requirements for grid leak-condenser detection with the CX-112A are that the plate voltage should be not more than 45 volts, the grid condenser should be about .00025 mfd. capacity and the grid leak should have a resistance of 2 to 9 megohms. For maximum sensitivity it is best to use the higher values of grid leak and for more stable operation, the lower values should be used.

AS AN AMPLIFIER

The CX-112A may be used as an R.F. or A.F. amplifier and should always be operated with the proper value of grid bias to secure maximum undistorted amplification. When used in the last audio stage, the power output can be calculated from the curve shown in Fig. 10.

RATING

Filament Voltage	5.0 volts
Filament Current25 amperes
Plate Voltage (maximum)	180 volts

AVERAGE CHARACTERISTICS

Plate Voltage	90	135	180 volts
Grid Bias Voltage	-4.5	-9	-13.5 volts
Amplification Factor	8.5	8.5	8.5
Mutual Conductance	1500	1600	1700 micromhos
Plate Resistance	5600	5300	5000 ohms
Plate Current	5.2	6.2	7.6 milliamperes
Undistorted Power Output	30	115	260 milliwatts
Grid-Plate Capacitance	8.1 mmf.		

DIMENSIONS

Maximum Overall Length	4 $\frac{1}{16}$ "
Maximum Overall Diameter	1 $\frac{3}{16}$ "
Base	Large CX

AVERAGE CHARACTERISTIC CURVES

(Pages 23 and 24)

Filament Characteristic—Fig. 6 shows the change of filament current with various filament voltages.

Plate Characteristics—Fig. 8 shows the relation between plate current and plate voltage at various bias voltages.

Mutual Characteristics—Fig. 7 shows a family of grid voltage-plate current curves at various plate voltages.

Dynamic Characteristics—Fig. 9 shows the effect of grid voltage upon the amplification factor, mutual conductance and plate resistance.

Output Characteristic—Fig. 10 shows the undistorted power output obtainable at various load resistances.

CX-371A

POWER AMPLIFIER TUBE

The CX-371A is a power amplifier tube designed for use in the last stage of an audio frequency amplifier. This tube employs a filament of the oxide coated type rated at 5.0 volts, 0.25 amperes, and is designed for alternating current or direct current operation.



Circuit Recommendations

Because of the high current flowing in the plate circuit some

sort of coupling device is desirable to prevent saturation or burn-out of the speaker coil. This coupling device may be a transformer or a choke coil and condenser. The transformer should have the proper ratio for the type of loud speaker used and the choke coil-condenser arrangement should have values of 10 to 30 henries and 2 to 6 microfarads, respectively.

If the power input to the CX-371A is supplied by a resistance coupled amplifier or a screen grid detector, the coupling circuit may contain a grid leak of not more than 1 megohm.

When a self biasing arrangement is used, the following resistance values will furnish satisfactory bias:

<i>Plate Voltage</i>	<i>Bias Resistance</i>
90	1580 ohms
135	1685 ohms
180	2150 ohms

When the volume requirements are such that maximum output is not needed, it is recommended that a low plate voltage be used.

RATING

Filament Voltage	5.0 volts
Filament Current	0.25 amperes
Plate Voltage (maximum)	180 volts

AVERAGE CHARACTERISTICS

Plate Voltage	90	135	180 volts
Grid Bias Voltage	-16.5	-27	-40.5 volts
Amplification Factor	3	3	3
Mutual Conductance	1330	1520	1620 micromhos
Plate Resistance	2250	1960	1850 ohms
Plate Current	12	17.5	20 milliamperes
Undistorted Power Output	125	370	700 milliwatts

DIMENSIONS

Maximum Overall Length	$4\frac{1}{16}$ "
Maximum Overall Diameter	$1\frac{1}{16}$ "
Base	Large CX

AVERAGE CHARACTERISTIC CURVES

(Pages 25 and 26)

Filament Characteristic—Fig. 11 shows the change of filament current with various filament voltages.

Plate Characteristics—Fig. 13 shows the relation between plate current and plate voltage at various bias voltages.

Mutual Characteristics—Fig. 12 shows a family of grid voltage plate current curves at various plate voltages.

Dynamic Characteristics—Fig. 14 shows the effect of grid voltage upon the amplification factor, mutual conductance and plate resistance.

Output Characteristic—Fig. 15 shows the undistorted power output obtainable at various load resistances.

BASE AND SOCKET CONNECTIONS

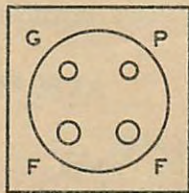
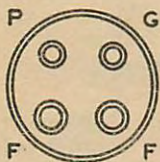

CX-301, CX-112A and CX-371A

CX-301A AVERAGE CHARACTERISTICS

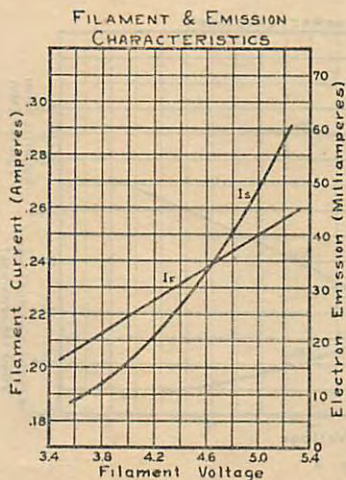

Fig. 1

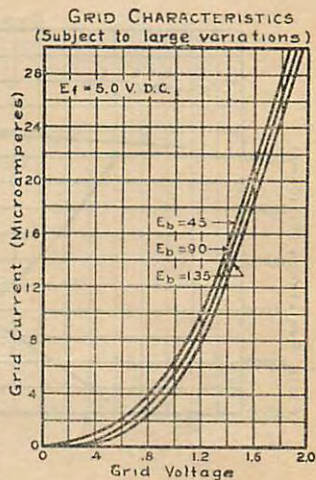

Fig. 2

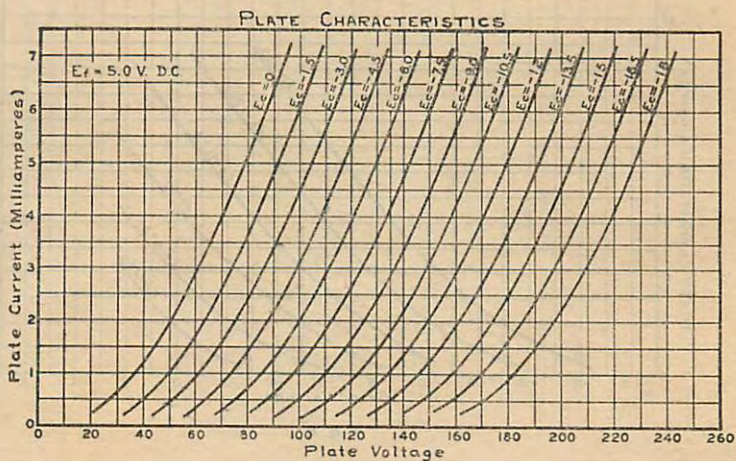

Fig. 3

CX-301A AVERAGE CHARACTERISTICS

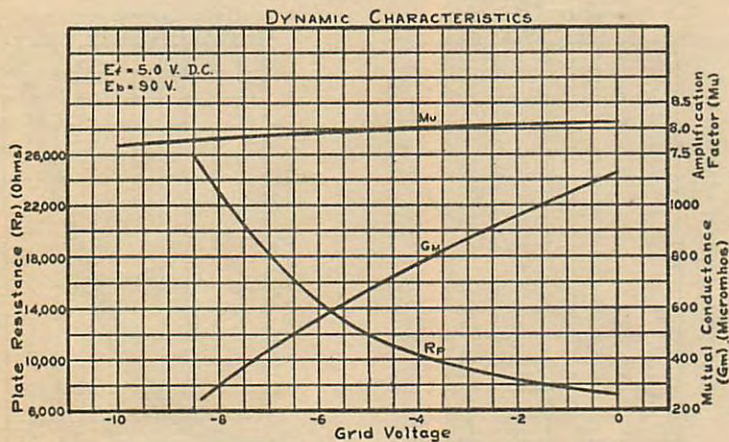

Fig. 4

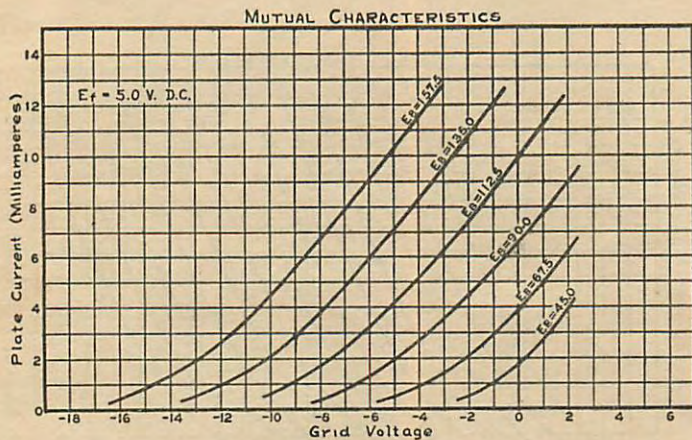

Fig. 5

CX-112A AVERAGE CHARACTERISTICS

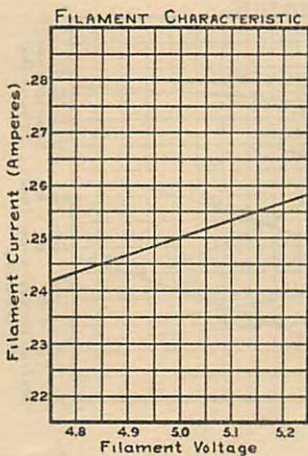

Fig. 6

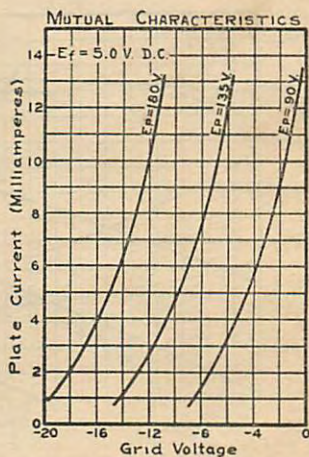

Fig. 7

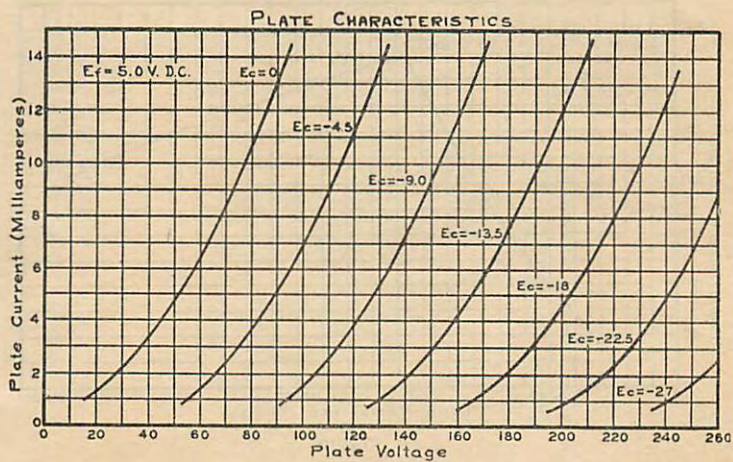

Fig. 8

CX-112A AVERAGE CHARACTERISTICS

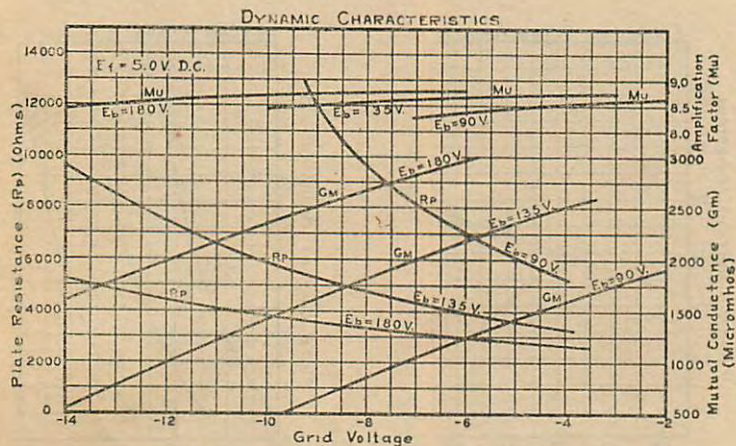

Fig. 9

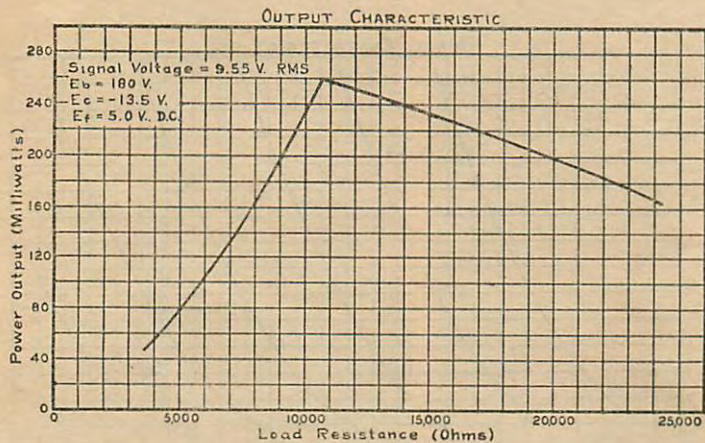

Fig. 10

CX-371A AVERAGE CHARACTERISTICS

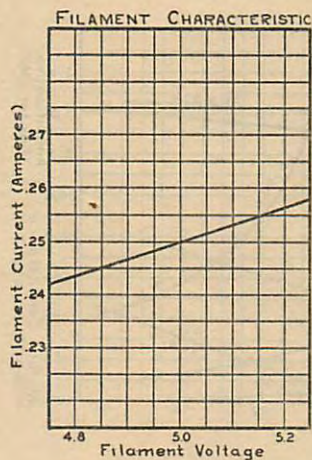

Fig. 11

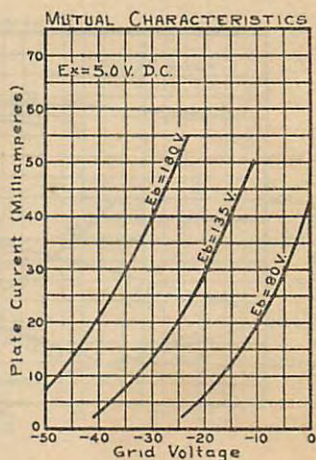

Fig. 12

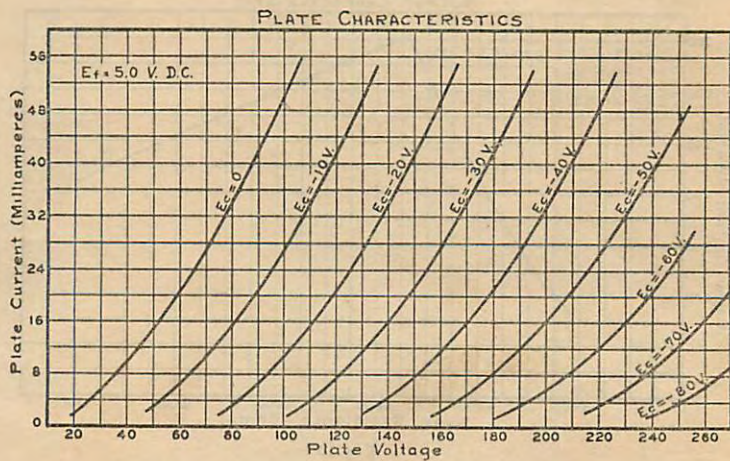

Fig. 13

CX-371A AVERAGE CHARACTERISTICS

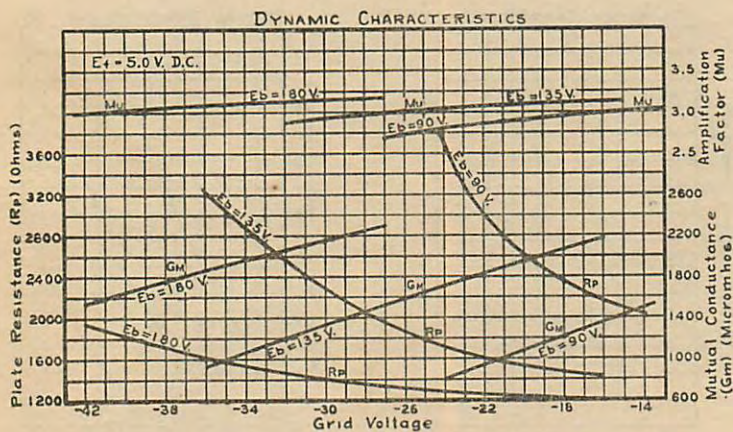

Fig. 14

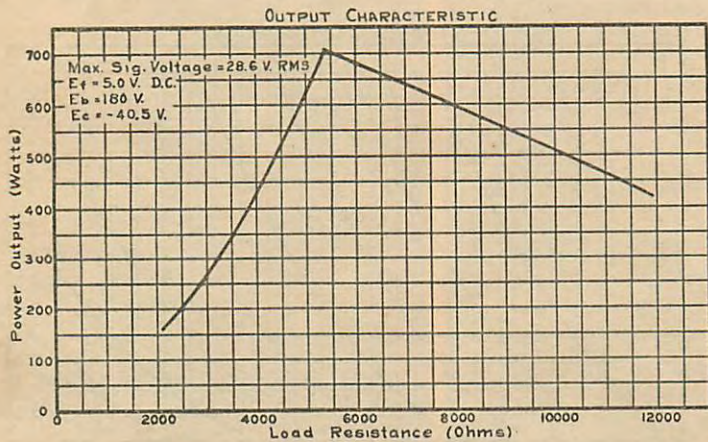

Fig. 15

Cunningham RADIO TUBES

BULLETIN

Type CX-322 Tube SCREEN GRID AMPLIFIER



1—Type CX-322 is a distinct departure from the conventional type of three element radio tube. The unusual characteristics and performance obtained from this tube are made possible by the introduction of a second grid, of novel design, which extends between the usual grid and the plate, and is also carried over outside the plate. Thus the plate is completely shielded or screened from the control grid by the second grid.

If the plate is left disconnected, and the screen grid used as the plate electrode, the tube operates in a manner exactly similar to the usual three element tube, having an amplification factor of 6.5 and a plate resistance of 15,000 ohms.

In operation as a four element tube a voltage of approximately 45 volts is applied to the screen grid, and a higher voltage (90 to 135 V.) is applied to the plate. The effect of this method of use upon the performance of the tube is explained in sections 6 to 8 below, dealing with the use as an amplifier.

2—BULB

The standard S-14 bulb (same as that used with type CX-301A) is used except that provision is made for a connection to the control grid on the top of the bulb, as indicated in the cut.

3—BASE

Standard CX. The usual grid terminal does not connect to the control grid as is the case with three element tubes, but to the screen grid.

4—FILAMENT

The filament provided in the CX-322 is rated at 3.3 volts, .132 amperes. For use with five volt tubes see rheostat recommendations, Section 12. When used as an R. F. amplifier only, the filament may be operated from an A. C. source by means of a step down transformer.

5—ELEMENTS

The control grid, cylindrical in form, is arranged in a manner similar to that of the CX-299, except that the connection to this element is brought out at the top of the bulb. The screen grid is interposed between the plate, which is also cylindrical, and the control grid, completely surrounding the plate as described above, and eliminating almost completely all electrostatic capacity between control grid and plate. The plate is larger in diameter than that used in type CX-299.

The somewhat complicated mechanical structure requires unusual skill in design to secure a rigid structure. The design has been very carefully worked out and the tube is more rugged than the average type of receiving tube.

6—USE AS DETECTOR

The tube may be used as a detector with grid leak and grid condenser or with grid bias. Resistance coupling with connections similar to those shown in the diagram on page 31, is recommended as giving the most satisfactory frequency characteristics because of the high internal resistance of the tube.

7—USE AS A RADIO FREQUENCY AMPLIFIER

This tube has been especially designed for use as an R. F. amplifier. When so used the most important advantage gained is elimination of all feed back through coupling between grid and plate, due to capacity between these elements. It is also possible to obtain higher voltage amplification per stage, 25 to 50 in the broadcast range as compared with the usual range of 5 to 12 per stage with three element tubes.

In the operating range the plate current does not vary appreciably with changes in plate voltage, this being due also to the screening effect of the second grid. As a result the amplitude of the plate current change, caused by a signal voltage impressed on the grid is scarcely affected by an increase in load resistance. Thus it is of advantage to use a very high resistance or impedance in the plate circuit, in order to obtain high voltage amplification.

The voltage amplification depends only upon two factors:

A—The mutual conductance of the tube, which determines the amplitude of the plate current change, resulting from a signal voltage impressed on the control grid, and—

B—The load impedance. The voltage across the output load is directly proportional to the local impedance, since the amplitude of the signal current, with moderate loads, remains unchanged with an increase in impedance. This is unlike the condition with three element tubes, where an increase in load resistance results in a decrease in the amplitude of the signal current.

At low radio frequencies, 50 to 100 kilocycles, it is possible to build up a very high load impedance by using a tuned plate circuit, and a voltage amplification of 200 per stage is obtainable. At broadcast frequencies it is not possible to obtain a sufficiently high load impedance to realize maximum voltage amplification, and the values quoted above represent average results (25 to 50 per stage).

Since the voltage amplification depends only upon the load impedance and mutual conductance it may be quickly computed when these values are known. The voltage amplification obtained with a load impedance of 100,000 ohms, using a tube having a value of mutual conductance of 350 micromhos (.00035 mhos.).

$$A_v = 100,000 \times .00035 = 35 \text{ per stage.}$$

With 250,000 ohms. $A_v = 250,000 \times .00035 = 87$ per stage.

It is possible to obtain the desired high load impedance by use of a tuned circuit connected in series with the plate, but it may be preferable to use a transformer connection with a ratio of 1:1 or slightly lower so that low frequency disturbances do not reach the grid of the succeeding tube and to facilitate the use of ganged condensers for uni-control. Both connections are shown in the circuit diagrams.

Although the internal shielding prevents feed back thru the tube interelectrode capacities, this is only one source of coupling between stages, and it is also necessary to shield the input circuit from the output circuit. The amount of shielding necessary will depend upon the voltage amplification per stage and the circuit design. A metallic shield enclosing each tuned stage

is usually sufficient, as indicated in the circuit diagram. It may be necessary, if the voltage amplification is high, to place a metal cap over the tube, extending to the base, and connected to ground. Clearance for the grid connection must be provided at the top.

8—USE AS AN AUDIO FREQUENCY AMPLIFIER

The tube may be used as an audio frequency amplifier with resistance coupling, the connections being the same as when the tube is used for radio frequency amplification, except that the screen grid voltage should be lowered to compensate for the voltage drop in the load, unless a high plate voltage is available. With this connection a voltage amplification of 35 per stage may be readily obtained with perfectly flat frequency characteristics down to 50 cycles and below (the lower limit is fixed only by the size of the blocking condenser); and extending on the high frequency and well above 10,000 cycles.

9—OPERATING CONDITIONS

Filament Volts	3.3
Filament Amperes132
Control Grid Volts (Average)	-1.5
Screen Grid Volts "	45.
Plate Volts	90 to 135

10—AVERAGE TUBE CHARACTERISTICS

Plate Voltage	135	135
Grid Voltage	-1.5	-1.5
Screen Grid Voltage	45	67.5
Amplification Factor	300	290
Plate Resistance (ohms)	850,000	600,000
Mutual Conductance (Micromhos)	350	480
Plate Current (Ma.)	1.5	3.3

11—INTERELECTRODE CAPACITY

Plate to control grid (max)025 mmf.
---------------------------------------	-----------

12—RHEOSTAT RECOMMENDATIONS

For use with 4.5 volt dry cells use a 20 to 30 ohm rheostat.

For use with 5 volt tubes; connect a fixed resistance of 15 ohms in series with the filament of the tube. It may then be connected in parallel with other 5 volt tubes, operating from a common rheostat. If placed in the negative lead a tap at 10 ohms will provide -1.3 volts bias for the control grid.

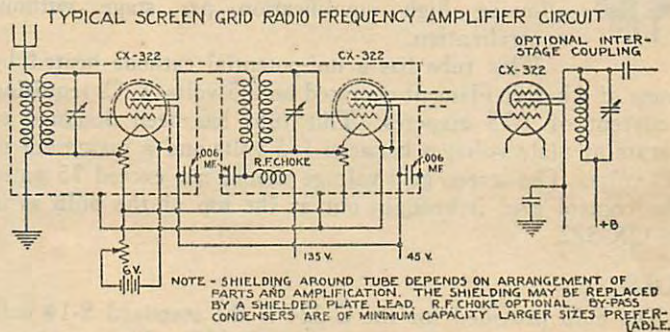

TYPICAL SCREEN GRID AUDIO FREQUENCY AMPLIFIER CIRCUIT

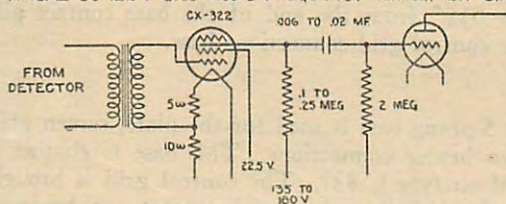

Cunningham RADIO TUBES

BULLETIN

Type C-324 Tube

SCREEN GRID AMPLIFIER AND DETECTOR



C-324 is a special purpose tube designed primarily as a radio frequency amplifier and high output bias detector. The design is similar to the design of type CX-322 in that it has a second grid of novel design which extends between the usual grid and plate and is also carried over the outside of the plate to give extremely good shielding between the control grid and the plate. The grid plate capacitance has been reduced to .01 mmfds. maximum allowing high amplification per stage without neutralization.

This tube has a uni-potential cathode heated by means of a heater filament operated on 2.5 volts A. C. requiring a current of 1.75 amperes. This tube has been designed to operate at plate voltages between 135 volts and a maximum of 180 volts. The screen grid voltage should not exceed 75 volts. The control grid is brought out at the top of the bulb as in the CX-322.

BULB

The bulb provided for the C-324 is the standard S-14 bulb having a maximum diameter of 1-13/16". The maximum overall length is 5 1/4" from the end of the base contact pins to the top of the control grid connections base.

BASE

The standard 5 prong base is used for the plate, screen grid, cathode, and two heater connections. This base is similar to the one employed on type C-327. The control grid is brought out at the top of the bulb to a special contact cap having a maximum diameter of .369". The control grid connection is made in this way to allow easy connection by means of a slotted cap which is placed over it. The base connections are shown in Fig. 8.

CATHODE-HEATER

The cathode is made of a small metal cylinder coated with the emission activating material. The heater or filament is placed

inside of the cathode. No connection is made between the cathode and heater in the tube.

ELEMENTS

The control grid is placed next to the cathode in the same way as used in the ordinary three electrode tube. The screen grid is placed between the control grid and plate and also extends on the outside of the plate to give complete plate-control grid shielding. The plate is cylindrical and slightly smaller in diameter than the outer section of the screen grid.

OPERATING CONDITIONS

Heater voltage	2.5	2.5 volts
Heater current	1.75	1.75 amperes
Plate voltage	180	180 volts maximum
Control grid voltage . . .	-1.5	-3.0 volts maximum
Screen grid voltage	75	90 volts maximum

AVERAGE TUBE CHARACTERISTICS

Tube characteristics at above operating conditions.

Amplification factor . . .	420	400
Plate resistance	400,000	400,000 ohms
Mutual conductance . . .	1,050	1,000 micromhos
Plate current	4.0	4.0 milliamperes

USE—AS A RADIO FREQUENCY AMPLIFIER

In order to obtain stable operation in circuits designed to give normal gain per stage it is necessary to use shielding to separate the input and output circuits. The internal shielding of the tube makes neutralization unnecessary providing extraneous external couplings are eliminated by means of shielding. Suitable ventilation must be provided through the shielding to prevent excessive tube temperatures. Radio frequency filters should be used in circuits employing more than two stages and also in circuits which are designed to give the maximum amplification per stage. The high plate circuit impedance necessary for obtaining the normal amplification may be obtained either with closely coupled RF transformers or by means of the tuned plate impedance method. At broadcast frequencies a voltage amplification from 50. to 100. per stage can be obtained. To prevent regeneration or oscillation in a two stage radio fre-

quency amplifier, the amplification should not exceed 100. per stage at the highest broadcast frequencies.

The volume of the RF amplifier may be controlled by a potentiometer control on the screen grid voltage so that the screen grid voltage may be varied between zero and plus 75 volts. Control grid voltage adjustment may also be used as volume control providing the control grid bias is always greater than 1.5 volts negative. The negative grid bias maintains high input resistance, resulting in good gain and selectivity of the preceding circuit.

USE—AS A DETECTOR

The C-324 is an excellent bias detector either with small signal or high signal input. The screen grid voltage and control grid bias should be so chosen that the control grid does not swing to a point where grid current is drawn. For small RF signals when a first audio stage is used it is best to operate the screen grid at 35 or 45 volts and the control grid at minus 3.5 or 4.5 volts, respectively. The output under this condition into a 200,000 ohm load choke fed with one volt RMS radio frequency input modulated 22%, is 5.5 volts RMS audio output. With 75 volts on the screen grid and a control grid bias voltage of 7.5 volts the audio output at the point where grid current starts is 49.5 RMS audio voltage output with an input of 4.28 volts RMS with 22% modulation. This is more than sufficient to operate a CX-345 to full output by means of direct coupling; or two CX-345 tubes in push pull by means of a low gain audio stage.

CURVES AND DATA—(Pages 36, 37 and 38)

Fig. 1 shows the filament current and emission variation with filament voltage.

Fig. 2 shows the average plate current over a range of screen grid voltages at various control grid voltages. A curve also of the screen grid current is plotted for the control grid voltage of negative 1.5 volts.

Fig. 3 shows the variation of amplification factor, plate resistance, and mutual conductance for various control grid voltages at screen grid voltages of 75 volts and plate voltage of 180 volts.

Fig. 4 shows the variation of amplification factor, plate resistance and mutual conductance with various screen grid volt-

ages at a control grid voltage of minus 1.5 volts and plate voltage of 180 volts.

Fig. 5 shows the variation of plate current with plate voltage for various control grid voltages at screen grid voltage of plus 75 volts.

Fig. 6 is similar to Fig. 5 except it has been plotted with a screen grid voltage of plus 45 volts.

Fig. 7 shows the detector action in audio frequency volts output against radio frequency input, both measured in RMS volts. The point where grid current starts to flow is noted on each curve. Curve A was taken at a plate voltage of 180 volts, a screen voltage of plus 45 volts and a control grid voltage of minus 4.5 volts. The plate voltage was fed through a high impedance choke and the resistance load so chosen to give a total plate circuit impedance of 200,000 ohms with a power factor of .96. The DC resistance of the choke was 3,000 ohms. Curve B was taken with the same circuit at a screen grid voltage of plus 75 volts and control grid voltage of minus 7.5 volts.

Fig. 8 shows a typical schematic circuit diagram with the C-324 employed as a radio frequency amplifier and detector. One method of shielding the circuits is suggested by the dotted lines.

Fig. 9 and Fig. 10 shows the base and socket connections.

The following are references to some of the articles which have been published describing the performance of the screen-grid tube in radio frequency amplifying circuits:

1. "Some Characteristics and Applications of Four-Electrode Tube," by J. C. Warner, Proceedings of Institute of Radio Engineers, Vol. 16, No. 4, April, 1928.
2. "Application of the Four-Electrode Receiving Tube," by Alan C. Rockwood and B. J. Thompson, Radio Engineering, July, Aug., 1928.
3. "The Screen-Grid Tube," by Keith Henney, Radio Broadcast, Jan., Feb., 1928.
4. "Circuit Analysis Applied to the Screen-Grid Tube," by J. R. Nelson, Proceedings of Institute of Radio Engineers, Vol. 17, No. 2, Feb., 1929.

C-324

AVERAGE CHARACTERISTICS

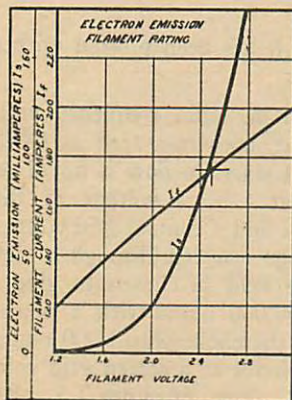

FIG 1

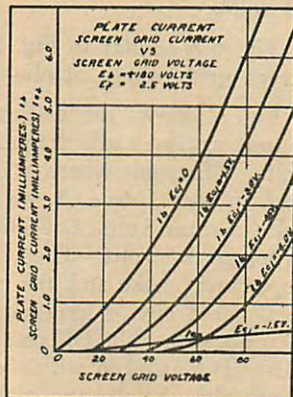

FIG 2

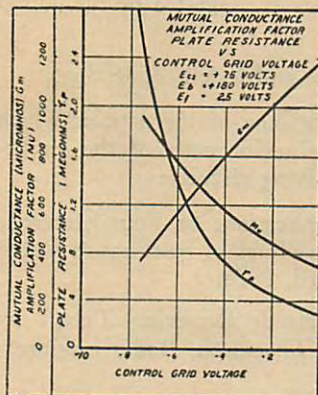

FIG 3

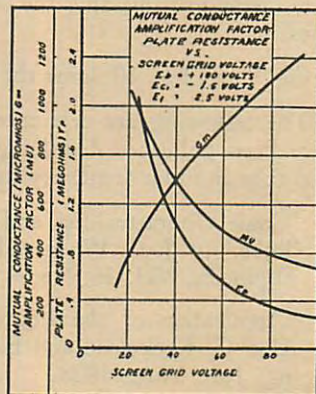

FIG 4

C-324 AVERAGE CHARACTERISTICS

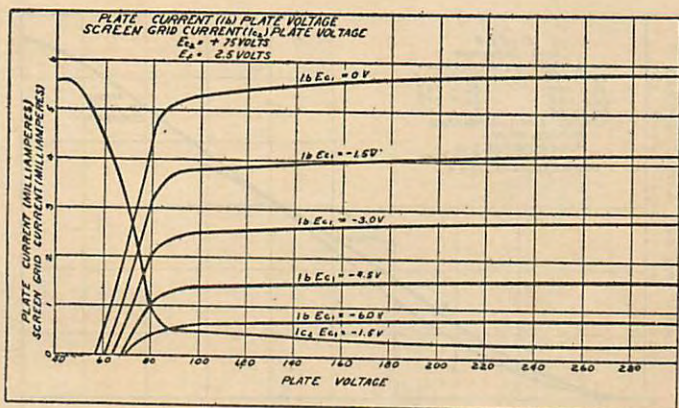

FIG 5

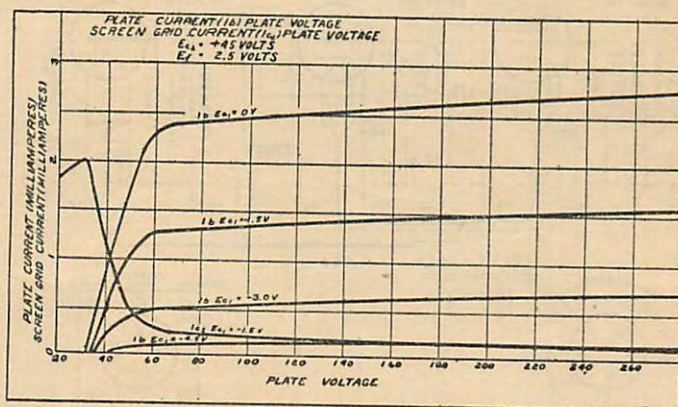

FIG 6

C-324 AVERAGE CHARACTERISTICS

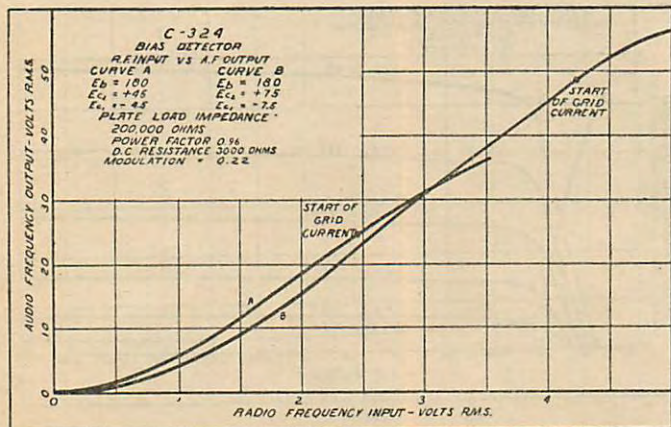
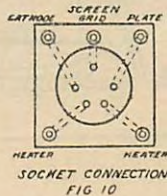
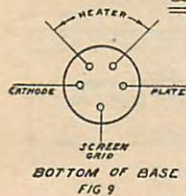
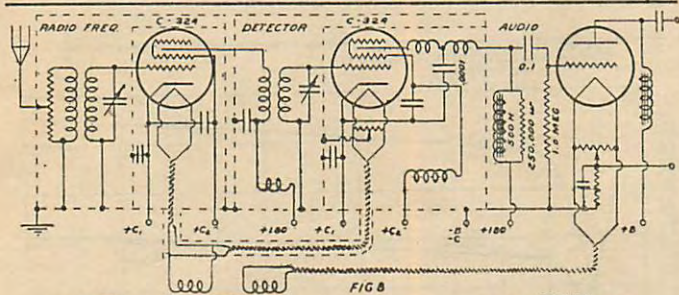

FIG 7



Cunningham RADIO TUBES

BULLETIN

Type CX-326

General Purpose Amplifier For A. C. Filament Operation

The CX-326 is a general purpose amplifier tube for use in radio frequency or audio frequency amplifier circuits. It is ordinarily not suited for use as a detector when A. C. is used on the filament. A specially selected coated ribbon filament is employed to permit operation from an A. C. source of supply of 1.5 volts and requiring 1.05 amperes filament current.



BULB

The bulb provided for the CX-326 is the standard S-14 having a maximum diameter of $1\frac{13}{16}$ ". The maximum overall length from the bottom of the base pins to the top of the bulb is $4\frac{11}{16}$ ".

BASE

The standard four prong base is employed with pins in the same position as in the CX-301A. The position of the pins is shown in figure 6.

FILAMENT

The filament is of the ribbon coated type arranged in the form of an inverted V, this design permitting operation from an A. C. source of power. The filament is of the low voltage high current type requiring 1.5 volts at a current of 1.05 amperes.

Filament leads should be of twisted pair being as short as possible. It is advisable to note that filament leads are not placed too near high potential leads in the circuit.

ELEMENTS

The same structural arrangement as employed in the CX-301A is utilized in the CX-326, that is, the surface of the grid and plate is oval shape with the grid placed next to the filament and the plate placed symmetrically about the grid. A mica disc is provided at the top of the construction which maintains rigid alignment of the elements.

OPERATING CONDITIONS

Filament Volts	1.5		
Filament Amperes	1.05		
Plate Volts	90	135	180
Grid Voltage	-6.0	-9.0	-13.5

AVERAGE TUBE CHARACTERISTICS

Plate Voltage.....	90	135	180
Grid Voltage.....	-6.0	-9.0	-13.5
C Bias Resistor.....	1700	1500	1800 ohms
Amplification Factor.....	8.2	8.2	8.2
Plate Resistance.....	8600	7200	7000 ohms
Mutual Conductance.....	955	1135	1170 micromhos
Plate Current.....	3.8	6.3	7.4 milliamperes
Undistorted Output.....	30	80	180 milliwatts

The higher plate voltages are recommended only where the signal input to a particular stage might be large enough to cause overloading or a flow of grid current.

USE—AS AN AMPLIFIER

Operation as an amplifier for either A.F. or R.F. is essentially the same as for the CX-301A. The electrical characteristics are substantially the same and ordinarily do not require any changes in the characteristics of the A.F. and R.F. transformers as previously employed with the CX-301A. Grid and plate return leads should be connected to the moveable arm of a low resistance potentiometer connected across the filament and in operation this arm should be adjusted for minimum hum.

The CX-326 cannot be used satisfactorily as a bias detector when operated from alternating currents as the hum present under such conditions is objectionable.

CURVES & DIAGRAMS—(Pages 41, 42 and 43)

The variation of filament current with filament voltage is shown in figure 1.

The relation between plate current and plate voltage at several values of bias is shown in figure 2. From this curve it is possible to determine approximately the plate current under given conditions of grid and plate voltage.

Figure 3 shows the variation of plate current with grid voltage for various values of plate voltage.

The effect of plate voltage upon amplification factor, plate resistance and mutual conductance at various grid bias voltages is shown in figure 4.

Figure 5 shows a suggested circuit arrangement for the use of the CX-326.

Socket connections are shown in figure 6.

CX-326

AVERAGE CHARACTERISTICS

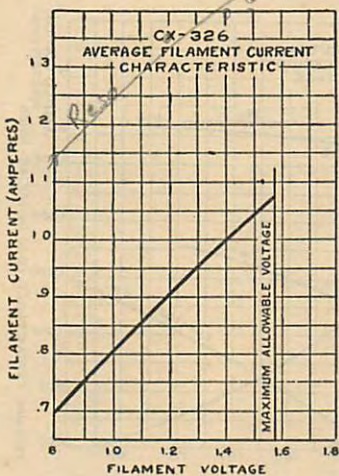

FIG. 1

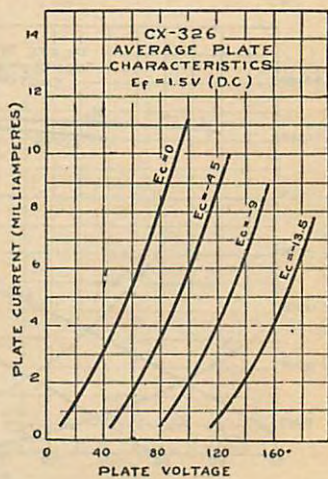

FIG. 2

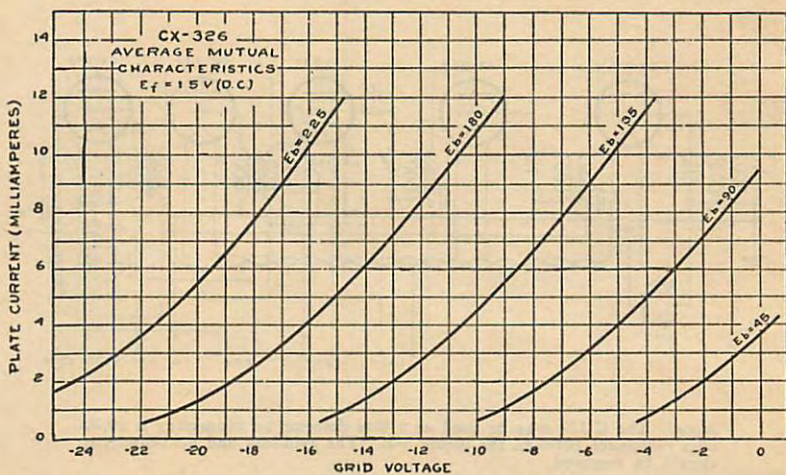

FIG. 3

CX-326 AVERAGE CHARACTERISTICS

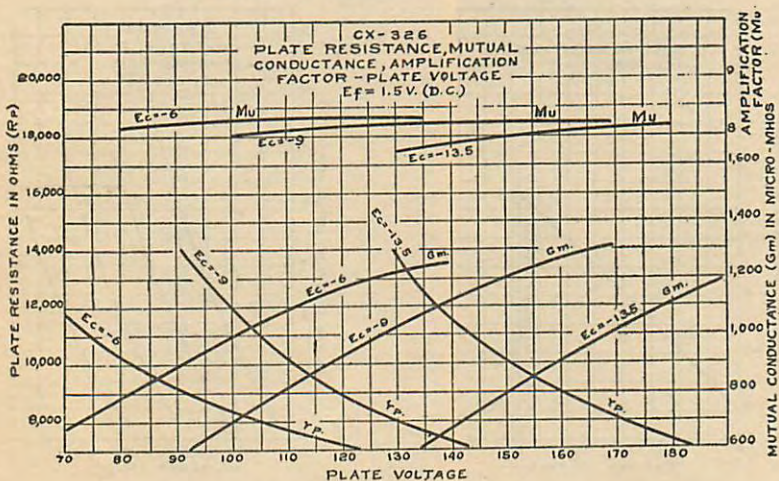
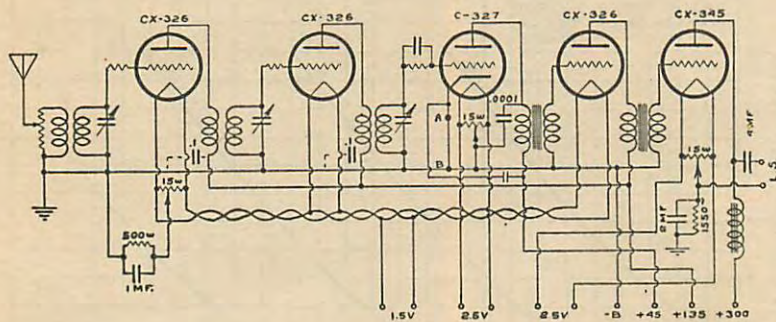
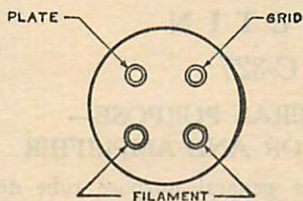

FIG. 4



Note: The C-327 may be used as a bias detector by connecting a 20,000 ohm resistance between the points A-B. The grid-leak and grid-condenser should be removed.

FIG. 5



**BOTTOM
OF BASE**

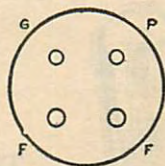

**SOCKET
CONNECTIONS**

FIG. 6

Cunningham RADIO TUBES

BULLETIN

Type C-327

GENERAL PURPOSE— DETECTOR AND AMPLIFIER



The C-327 is a general purpose tube designed primarily as an amplifier and for either grid leak or bias detection. The tube employs a uni-potential cathode indirectly heated by means of a heater filament to permit filament operation from an A. C. supply of 2.5 volts at a current of 1.75 amperes.

BULB

The bulb provided for the C-327 is the standard S-14 bulb having a maximum diameter of $1\frac{13}{16}$ ".

The maximum overall length of the bulb from the bottom of the base pins to the top of the bulb is $4\frac{11}{16}$ ".

BASE

A five prong base is used for plate, grid and two heater connections with the fifth prong being used for the cathode connection. The position of the pins is shown in figure 7.

CATHODE-HEATER

The cathode is made of a short cylinder of small diameter on which is coated the emissive material. The heater or filament is placed inside the cathode. No connection is made between these two elements inside the tube.

Where several sockets are connected in parallel, it is recommended that the heater leads from the supply to each socket be of twisted wire of equal lengths so as to insure uniform heater voltages.

ELEMENTS

A cylindrical structure is employed with the grid placed next to the cathode and a plate placed around the grid.

OPERATING CONDITIONS

Plate Volts	Detection		Amplification
	Grid Leak (Megs)	Grid Bias (Volts)	Grid Bias (Volts)
45	2	-5.0	
90		-10.0	-6.0
135		-15.0	-9.0
180		-20.0	-13.5

The higher plate voltages are recommended only where the signal input to a particular stage might be large enough to cause overloading or a flow of grid current.

AVERAGE CHARACTERISTICS

Plate Voltage	90	135	180
Grid Voltage	-6.0	-9.0	-13.5
C Bias Resistor	2200	2000	2700 ohms
Amplification Factor	9.0	9.0	9.0
Plate Resistance	11000	9000	9000 ohms
Mutual Conductance	820	1000	1000 micromhos
Plate Current	2.7	4.5	5.0 milliamperes
Undistorted Output	30.	80.	165. milliwatts

USE—AS AN AMPLIFIER

The C-327 due to its low AC ripple voltage in the plate circuit is well suited for radio and audio frequency amplification. The average grid plate capacity is 3.3 micro-microfarads. When used as a radio frequency amplifier this feedback capacity must be compensated for by means of neutralization or introduction of resistance in series with the grid.

The operation of the C-327 as an amplifier is essentially the same as for the CX-301A. Grid and plate return leads are connected to the cathode and in addition the center tap of the filament transformer is connected directly to the cathode. In some instances it might be desirable, in order to minimize hum to use a potentiometer return instead of the transformer center tap.

It is recommended that the grid bias be obtained from the plate current voltage drop in a resistor between cathode and the minus B connection, as this connection tends to stabilize variations in operation characteristics resulting from variation in operating voltages.

USE—AS A DETECTOR

The C-327 is an excellent grid leak detector and for small signal input a two meg. grid-leak and a .00025 mfd. grid condenser will be satisfactory. The excellent detector sensitivity obtained with this tube may be realized by referring to figure 5 which shows the relation between the modulated R. F. input and A. F. output for small signal inputs.

The C-327 is well adapted for use as a bias detector and can be used to advantage as such in circuits where the R. F. amplification is large enough to swing the detector grid over the maximum per-

missable grid voltage range. Figure 6 shows the audio voltage available as a high output bias detector. It is obvious from an inspection of the curves how the increased plate and grid voltages permit a larger audio output.

Referring to the table of the various operating voltages as a bias detector, it is seen that the best value of bias to be used for a given plate voltage with this tube is approximately 1/9th of the plate voltage.

It is recommended that the bias to operate the C-327 as a bias detector be obtained from the plate current drop in a resistor between cathode and the minus B connection. The value of this bias resistance is not critical and satisfactory results may be obtained with a resistor of 20,000 to 100,000 ohms resistance. The higher value will allow larger signal input without overloading while, with low output coupling impedance, lower values are preferable.

A plate load of approximately 100,000 ohms impedance will be satisfactory and can generally be obtained from shunting a 100,000 ohm resistance across a high impedance choke.

CURVES & DIAGRAMS—(Pages 47, 48 and 49)

Figure 1 shows the variation of filament current with filament voltage.

Figure 2 shows the variation of plate current with plate voltage for various values of bias voltage.

Figure 3 shows the variation of plate current with grid voltage for various values of plate voltage.

Figure 4 shows the variation of amplification factor, plate resistance and mutual conductance with grid voltage for various values of plate voltage.

Figure 5 shows the detector action as a grid leak detector with plate voltage of 45 volts, 2 meg grid leak and for 22% modulation.

Figure 6 shows the detector action of the C-327 operating as a bias detector under various voltage conditions, with a plate load of 200,000 ohms and 22% modulation. The star marked on each curve indicates the point at which grid current begins to flow.

Figure 7 shows the base pins and socket connections.

Figure 8 shows a suggested circuit arrangement using the C-327 both as an amplifier and detector.

C-327 AVERAGE CHARACTERISTICS

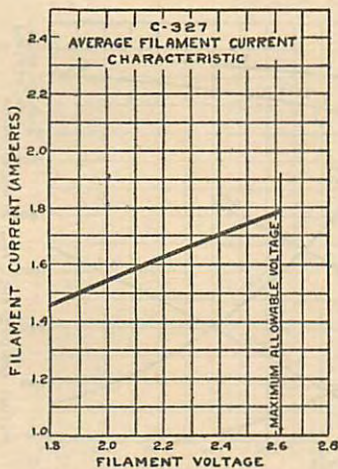

FIG. 1

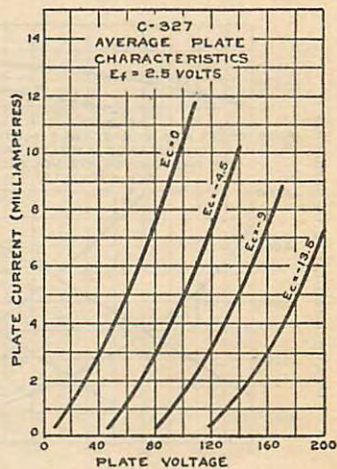

FIG. 2

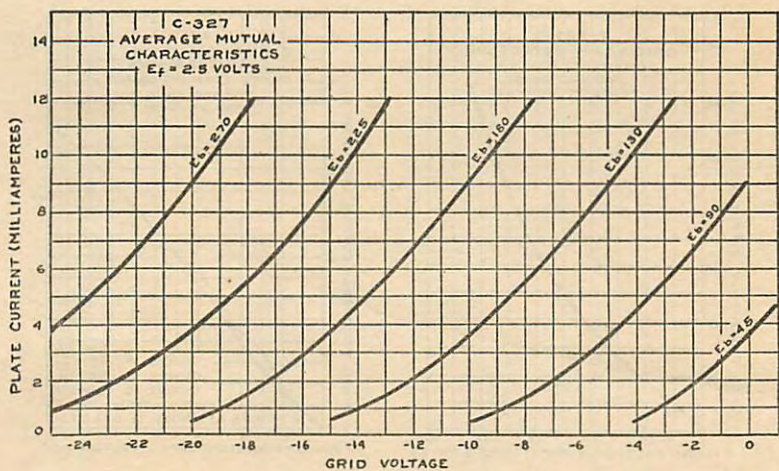

FIG. 3

C-327 AVERAGE CHARACTERISTICS

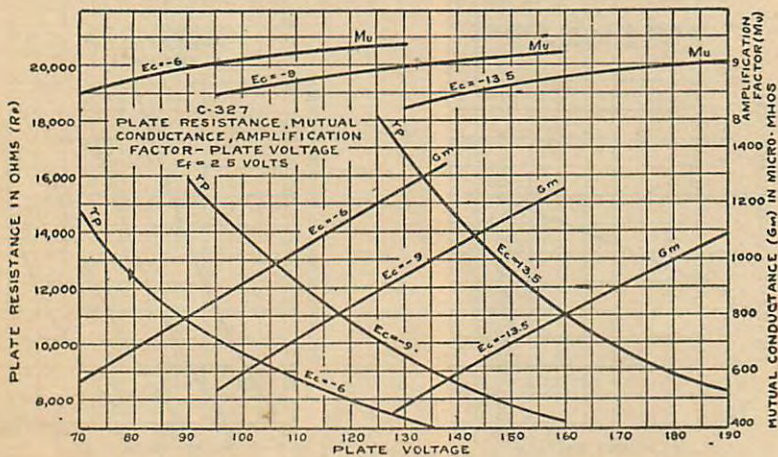

FIG. 4

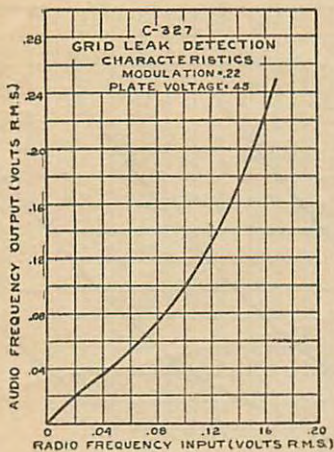

FIG. 5

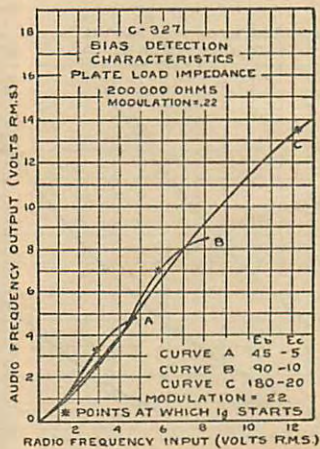

FIG. 6

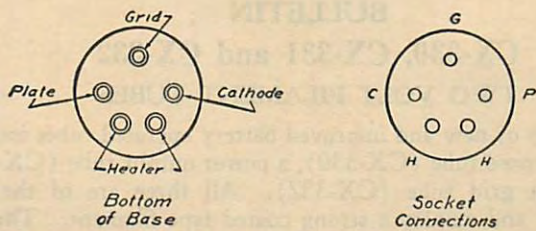

FIG. 7

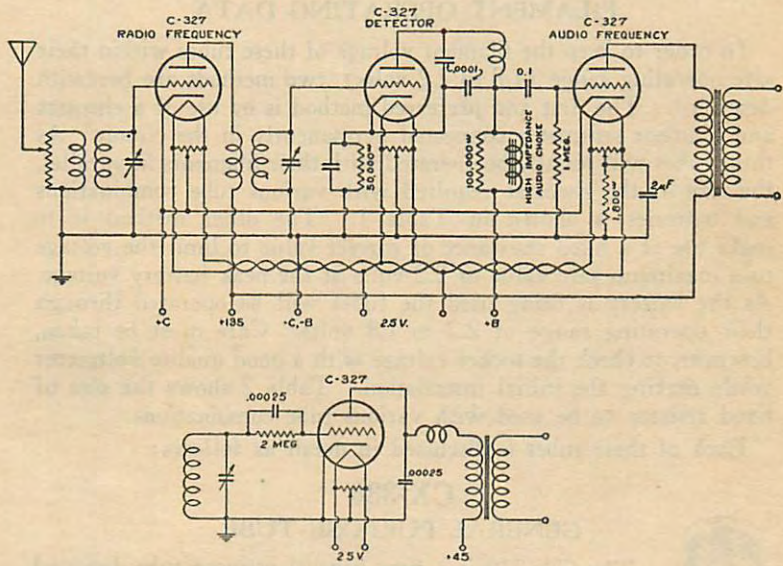

FIG. 8

Cunningham RADIO TUBES

BULLETIN

CX-330, CX-331 and CX-332

TWO VOLT FILAMENT TUBES

This group of new and improved battery operated tubes includes a general purpose tube (CX-330), a power output tube (CX-331) and a screen grid tube (CX-332). All three are of the high vacuum type and employ a strong coated type filament. The filament in each type has been carefully designed to take as little power as possible, consistent with satisfactory operating performance. These tubes are particularly suited for use in radio receivers operating either from dry cells or from a storage battery where economy of filament current drain is important.

FILAMENT OPERATING DATA

In order to keep the filament voltage of these tubes within their safe operating range (1.8 to 2.2 volts), two methods are herewith described. The first and preferred method is by use of a rheostat and filament voltmeter connected permanently in the circuit. As these tubes will usually be operated with their filaments in parallel, the size of the rheostat required with various tube combinations and batteries is shown in Table 1. The other method is to make use of a fixed resistance of correct value to limit the voltage to a maximum safe value of 2.2 volts at the peak battery voltage. As the battery is being used the tubes will be operated through their operating range of 2.2 to 1.8 volts. Care must be taken, however, to check the socket voltage with a good quality voltmeter while making the initial installation. Table 2 shows the size of fixed resistor to be used with various tube combinations.

Each of these tubes is discussed in detail as follows:

CX-330

GENERAL PURPOSE TUBE

The CX-330 is a new general purpose tube designed to operate in battery receivers where economy of filament consumption is important. It may be used as a detector or amplifier and has an appearance similar to the CX-299, but has electrical characteristics which are considerably better. By using the CX-330 with the CX-331 (power tube) and CX-332 (screen grid tube) it is possible to construct a modern radio receiver having screen grid R.F. amplification and a power output stage.



FILAMENT

The CX-330 has a coated type filament which operates at a normal voltage of 2 volts and a current of 60 milliamperes. This filament power can conveniently be supplied from dry or storage batteries. Although the normal filament voltage is two volts, this tube has been so designed that it will give excellent operation at voltages slightly above and below the specified two volts. However, it is absolutely essential that the voltage is never above 2.2 volts or its life will be seriously shortened. Operation below 1.8 volts is not recommended.

PLATE AND GRID

The plate of this new general purpose tube is of the oval construction resulting in good mutual conductance with the extremely small filament consumption. The grid is also of oval construction and has been so designed to give the greatest possible operating characteristics.

The maximum recommended plate voltage for the CX-330 is 90 volts. At this voltage with the proper grid bias of -4.5 volts, the average plate current is 1.8 milliamperes. This value should be regarded as an average and tubes will be found to vary somewhat above and below this value.

Circuit Recommendations

AS AN R.F. AMPLIFIER

The CX-330 may be used in circuits of conventional design, as a radio frequency amplifier in which case the grid and plate circuit return should be completed through correct batteries to the negative filament terminal of the tube. It is also possible to reduce the plate voltage to 67.5 volts and the grid bias to -3.0 volts and still secure proper amplification.

It is not recommended that a rheostat be used as a volume control unless provision is made, that the highest voltage applied to the filament is never above 2.2 volts.

AS A DETECTOR

When used as a detector with grid leak and condenser, the plate voltage should not be higher than 45 volts and the grid return

should be connected to the positive side of the filament. The grid condenser should have a capacitance of .00025 mfd. and the grid-leak a resistance of from $\frac{1}{4}$ to 5 megohms. The higher the value of grid-leak, the greater will be the sensitivity on very weak signals, but the fidelity will be somewhat inferior to that obtained with the lower value.

The grid bias method of detection is recommended where better quality and selectivity is desired at the expense of sensitivity. The following table gives the approximate grid voltages to be used for a number of different plate voltages. Plate voltages above 90 volts should only be used when operating as a bias detector at the grid bias recommended below. The values of E_p are actual plate-filament voltages. The "B" battery voltage is higher by the drop in the plate resistance if resistance coupling is used.

E_p	E_g
90	-10.5
135	-15.0
165	-18.0

AS AN A.F. AMPLIFIER

As in R.F. amplification the grid return should be connected to the negative filament terminal, when the CX-330 is used as an A.F. amplifier. With resistance coupling the grid resistance should not be greater than 2 megohms.

SUBSTITUTION FOR OTHER CUNNINGHAM TUBES

The CX-330 may be substituted for the CX-299 in sets using the latter, providing suitable precautions are taken to limit the filament voltage to 2.0 volts. In tuned radio frequency receivers, it may be necessary to readjust the neutralizing condenser or grid resistor before stable operation is obtained.

OPERATING CONDITIONS

Filament Voltage	2.0 volts
Filament Current	0.06 amperes
Plate Voltage (maximum)	90 volts
Grid Bias Voltage	-4.5 volts

AVERAGE CHARACTERISTICS

Amplification Factor	9.3
Mutual Conductance	700 micromhos
Plate Resistance	13000 ohms
Plate Current	1.8 milliamperes
Maximum Undistorted Power Output . .	16 milliwatts
Grid-Plate Capacitance	6.0 mmf.
Grid-Filament Capacitance	3.5 mmf.
Plate-Filament Capacitance	2.0 mmf.

DIMENSIONS

Maximum Overall Length	4 $\frac{1}{4}$ "
Maximum Overall Diameter	1 $\frac{3}{16}$ "

BASE

The new small CX type base is employed on this tube. This base has the same maximum diameter as the base used on the CX-299 and CX-220 tubes but instead of the tapered shell a straight side shell is used. This new style base was developed for the slightly larger bulb size employed in the CX-330. The standard CX pin dimensions and connections are employed.

AVERAGE CHARACTERISTIC CURVES

(Pages 61 and 62)

Filament Characteristic—Fig. 1 shows the change of filament current with various filament voltages.

Grid Characteristic—Fig. 2 shows the relation between grid current and voltage.

Plate Characteristics—Fig. 3 shows a family of plate voltage-plate current curves at various grid bias voltages.

Mutual Characteristics—Fig. 5 shows a family of grid voltage-plate current curves for various plate voltages.

Dynamic Characteristics—Fig. 4 shows the effect of plate current upon the amplification factor, mutual conductance and plate resistance.

Detector Characteristics—Fig. 6 shows the relation between the radio frequency input and the audio frequency output, for several percentages of modulation.

CX-331

POWER AMPLIFIER



The CX-331 is a new power amplifier tube designed to give good output volume from battery operated receivers where economy of filament consumption is important. It is the power output member of the "Two Volt Line" which has been developed for economical battery operation. The other tubes in this line are the CX-330 (general purpose tube) and the CX-332 (screen grid tube). By employing these three types of tubes, it is possible to construct a modern radio receiver employing screen grid tubes for R.F. amplification, general purpose tubes for detection and first audio amplification, and this special tube for power output purposes.

The power output of CX-331 is 150 milliwatts which is probably sufficient for loud speaker operation in portable sets but where additional loud speaker volume is required two of these tubes may be used in push-pull to give sufficient volume for ordinary home reception when an efficient loud speaker is used.

FILAMENT

The CX-331 has a coated type filament which operates at a normal voltage of 2 volts and a current of 130 milliamperes. The filament should be operated in accordance with the data specified on page 50.

PLATE AND GRID

The plate of this new power output tube is of the oval construction. This type of plate results in extremely good mutual conductance or power output capabilities with extremely small filament consumption. The grid is also of oval construction and its spacing and wire size has been so chosen to give the greatest possible power output with the limitations of the small amount of filament power consumed. The maximum recommended plate voltage for the CX-331 is 135 volts. At this voltage with the proper grid bias, the average plate current is 6.8 milliamperes. This value should be regarded as an average and tubes will be found to vary somewhat around it.

This tube should always be operated with a grid bias of $-22\frac{1}{2}$ volts and precautions should be taken to prevent operation without this required voltage.

CIRCUIT RECOMMENDATIONS

Tables No. 1 and 2 give the recommended rheostat or fixed resistance values to control the filament voltage. The load resistance for maximum undistorted power output should be approximately 9,000 ohms when the tube is operated with 135 volts on the plate. In resistance coupled amplifiers a grid resistor should have a value of 1 megohm or less. The use of a self-biasing voltage supply is recommended where it is possible to obtain it economically. A typical circuit diagram using the CX-331 connected in push-pull is shown in Fig. 19.

SUBSTITUTION FOR OTHER CUNNINGHAM TUBES

Although it is not generally recommended that CX-331 be used as a substitute for the CX-220, it may be employed by making circuit changes. It will be necessary to provide the proper filament voltage by means outlined under the filament heading. It is also very essential that the proper plate and grid bias voltage be used and in all cases, the initial installation of CX-331 should be carefully made and checked with a good voltmeter.

OPERATING CONDITIONS

Filament Voltage	2.0	volts
Filament Current	0.130	amperes
Plate Voltage (maximum)	135	volts
Grid Bias Voltage	-22.5	volts

AVERAGE CHARACTERISTICS

Amplification Factor	3.8
Mutual Conductance	760 micromhos
Plate Resistance	4950 ohms
Plate Current	6.8 milliamperes
Maximum Undistorted Power Output	150 milliwatts
Grid-Plate Capacitance	6.0 mmf.
Grid-Filament Capacitance	3.5 mmf.
Plate-Filament Capacitance	2.0 mmf.

DIMENSIONS

Maximum Overall Length	4 $\frac{1}{4}$ "
Maximum Overall Diameter	1 $\frac{3}{16}$ "

BASE

The new small CX type base is employed on this tube. This base has the same maximum diameter as the base used on CX-299 and CX-220 tubes but instead of the tapered shell a straight side shell is used. This new style base was developed for the slightly larger bulb size employed for CX-331. The standard pin dimensions and connections are employed.

AVERAGE CHARACTERISTIC CURVES

(Pages 63 and 64)

Filament Characteristic—Fig. 7 shows the change of filament current with various filament voltages.

Plate Characteristics—Fig. 9 shows the relation between plate current and plate voltage at various bias voltages.

Mutual Characteristics—Fig. 8 shows a family of grid voltage-plate current curves at various plate voltages.

Dynamic Characteristics—Fig. 10 shows the effect of plate current upon the amplification factor, mutual conductance and plate resistance.

Output Characteristic—Fig. 11 shows the undistorted power output obtainable at various load resistances.

CX-332

SCREEN GRID TUBE



The CX-332 is a new screen grid tube designed for use as a radio frequency amplifier or detector in battery operated receivers where economy of filament consumption is important. This tube used with the others of the new "Two Volt Filament" type, makes possible the construction of a most modern type of receiver operating with much greater economy than has heretofore been possible when using batteries.

The amplification factor of the CX-332 is 580 and the control grid to plate capacity is 0.020 mmf. This high amplification factor and low control grid to plate capacitance makes possible a high voltage amplification per stage.

FILAMENT

The CX-332 has a coated filament which operates at a normal voltage of 2.0 volts and a current of 60 milliamperes. The filament should be operated in accordance with the data specified on page 50.

PLATE, CONTROL GRID AND SCREEN GRID

The plate of this new screen grid tube is of circular construction, being similar to that used in the CX-322, while the control grid is spiral shaped and has its terminal *on the top* of the bulb. This control grid is electrostatically shielded from the plate by the introduction of an extra electrode called the screen grid.

The maximum recommended plate voltage for the CX-332 is 135 volts. At this voltage with a screen grid voltage of 67.5 and a proper grid bias of -3.0 volts, the average plate current is 1.4 milliamperes.

Circuit Recommendations

AS AN R.F. AMPLIFIER

Stable operation of this screen grid tube in circuits designed to give maximum gain per stage requires separation of the input and output circuit elements. Internal shielding of the screen makes neutralization of the plate to grid capacity unnecessary. However, the high amplifying ability of this tube makes it essential to prevent external coupling between circuit elements if the full capabilities of the tube are to be obtained. In general, with multi-stage amplifier circuits, it is necessary to use complete stage shielding including all the components of each stage. It is particularly necessary to shield the control-grid circuit from the plate circuit.

The use of filters in all leads entering the stage shields may be necessary in high gain amplifiers to reduce coupling in external parts of the circuits. In the construction of filters for the screen circuit, a by-pass condenser should be provided to keep the impedance from screen to ground as low as possible.

In general, properly designed radio-frequency transformers are preferable to impedances for inter-stage coupling. If, however, impedance coupling is used, the grid resistance should not exceed 2.0 megohms.

AS A DETECTOR

The CX-332 may be used as a detector providing the audio amplification is comparatively low in order to prevent microphonic disturbances. The audio gain permissible depends on the type of cabinet, speaker design, and power output capabilities of the power output tubes. In any circuit a cushion type socket is recommended. The following operating conditions are suggested:

Screen Grid Voltage	67.5	45
Control Grid Bias Voltage	-6	4.0
Plate Load Resistor	100000	100000

The Plate Battery Supply Voltage may be either 135 or 157.5 volts.

In addition to its recommended application as a screen grid-radio-frequency amplifier this new tube may be employed in experimental circuits wherever a double grid, four-electrode tube is desired.

In circuits designed for CX-322, the CX-332 may be substituted providing the filament and grid circuit voltages are altered to conform to the requirements of this new tube. A typical circuit diagram using the CX-332 as an R.F. amplifier is shown in Fig. 19.

OPERATING CONDITIONS

Filament Voltage	2.0	volts
Filament Current	0.06	amperes
Plate Voltage	135	volts
Control Grid Voltage	-3	volts
Screen Grid Voltage	67.5	volts

AVERAGE CHARACTERISTICS

Amplification Factor	580	
Mutual Conductance	505	micromhos
Plate Resistance	1150000	ohms
Plate Current	1.4	milliamperes
Grid-Plate Capacitance	0.020	mmf.
Input Capacitance	6.0	mmf.
Output Capacitance	11.0	mmf.

DIMENSIONS

Maximum Overall Length	4 $\frac{1}{16}$ " to 5 $\frac{1}{4}$ "
Maximum Overall Diameter	1 $\frac{3}{16}$ "

BASE

Standard CX (no side pin).

AVERAGE CHARACTERISTIC CURVES

(Pages 65 and 66)

Filament Characteristics—Fig. 12 shows the change of filament current with various filament voltages.

Inter-Electrode Characteristics—Figs. 13, 14 and 15 show the relations existing between the plate, control grid and screen grid by means of the following curves:

Plate Voltage—Plate Current	Fig. 14
Plate Voltage—Screen Grid Current	Fig. 14
Control Grid Voltage—Plate Current	Fig. 13
Control Grid Voltage—Screen Grid Current	Fig. 13
Screen Grid Voltage—Plate Current	Fig. 15
Screen Grid Voltage—Screen Grid Current	Fig. 15

Dynamic Characteristics—Figs. 17 and 18 show the effect of control grid and screen grid voltage (respectively) upon the amplification factor, mutual conductance and plate resistance of the CX-332.

Detection Characteristics—Fig. 16 shows the relation between the radio frequency input and the audio frequency output, for several percentages of modulation.

TABLE I

Rheostat Values for Two Volt Filament Tubes—(Minimum)

Number of CX-330's or CX-332's	Two Dry Cells (3.0V.)		Two Edison Cells (2.8V.)	
	1 CX-331	2 CX-331's	1 CX-331	2 CX-331's
1	6 ohms	5 ohms	5 ohms	3 ohms
2	5 "	3 "	4 "	2.5 "
3	4 "	3 "	3 "	2 "
4	3 "	2 "	2.5 "	1.8 "
5	3 "	2 "	2 "	1.5 "
6	2.5 "	2 "	1.8 "	1.5 "
7	2 "	1.5 "	1.5 "	1.3 "

TABLE II

Fixed Resistance Values for Two Volt Filament Tubes

Number of CX-330's or CX-332's	Two Dry Cells (3.0V.)		Two Edison Cells (2.8V.)	
	1 CX-331	2 CX-331's	1 CX-331	2 CX-331's
1	4.2 ohms	2.5 ohms	3.2 ohms	1.9 ohms
2	3.2 "	2.1 "	2.4 "	1.6 "
3	2.6 "	1.8 "	1.9 "	1.4 "
4	2.2 "	1.6 "	1.6 "	1.2 "
5	1.9 "	1.4 "	1.4 "	1.1 "
6	1.6 "	1.3 "	1.2 "	1.0 "
7	1.5 "	1.2 "	1.0 "	0.9 "

NOTE: No resistances are needed when using a single cell storage battery

CX-330 AVERAGE CHARACTERISTICS

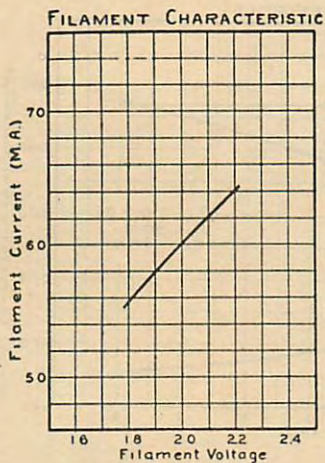

Fig. 1

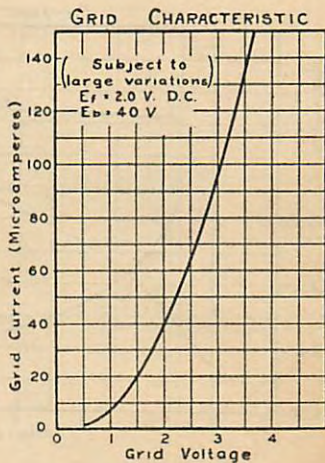

Fig. 2

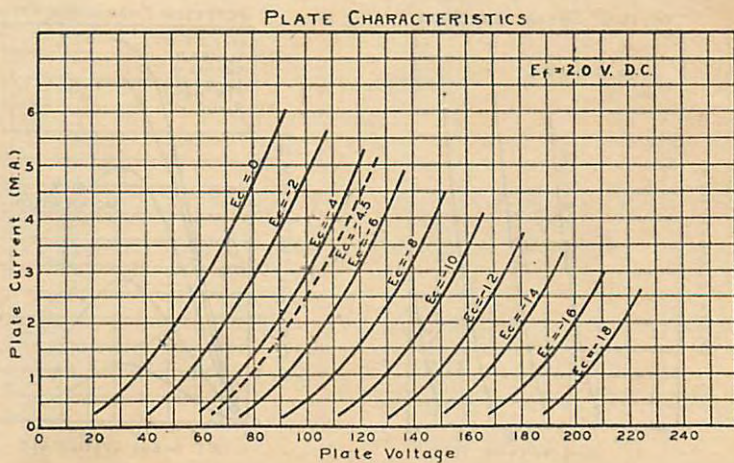

Fig. 3

CX-330 AVERAGE CHARACTERISTICS

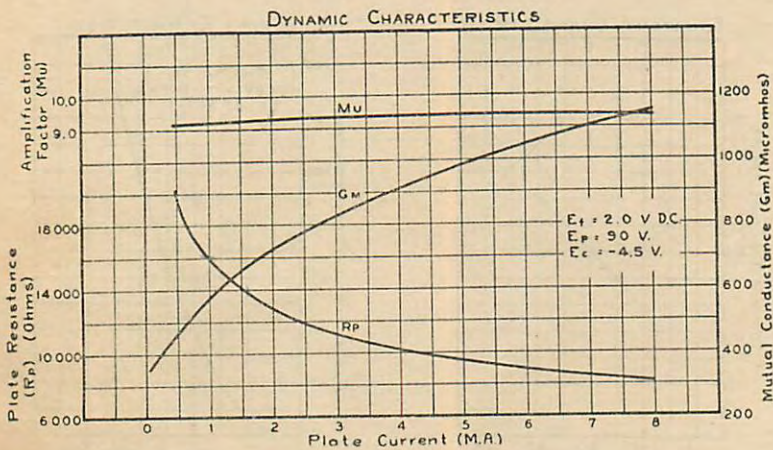

Fig. 4

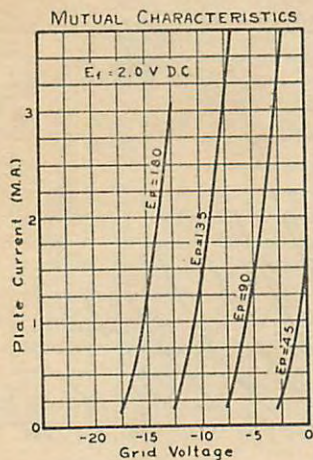

Fig. 5

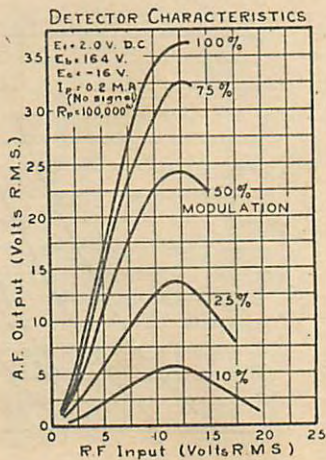

Fig. 6

CX-331 AVERAGE CHARACTERISTICS

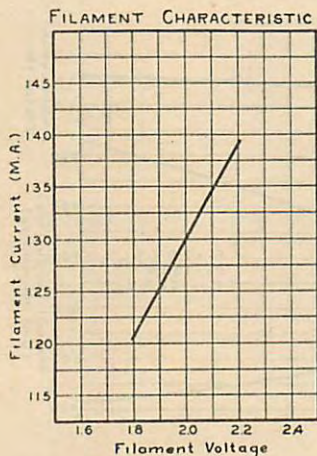

Fig. 7

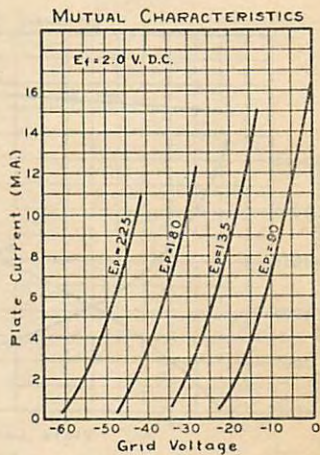

Fig. 8

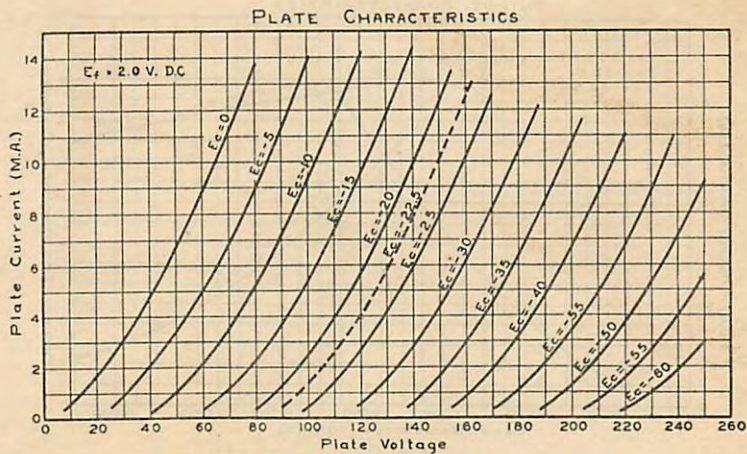

Fig. 9

CX-331 AVERAGE CHARACTERISTICS

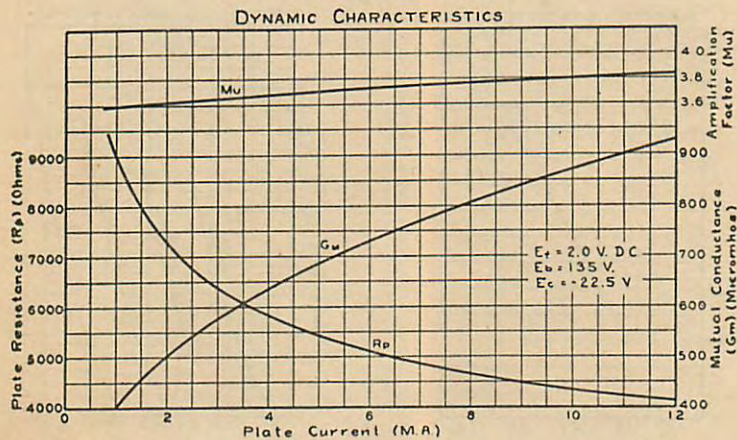

Fig. 10

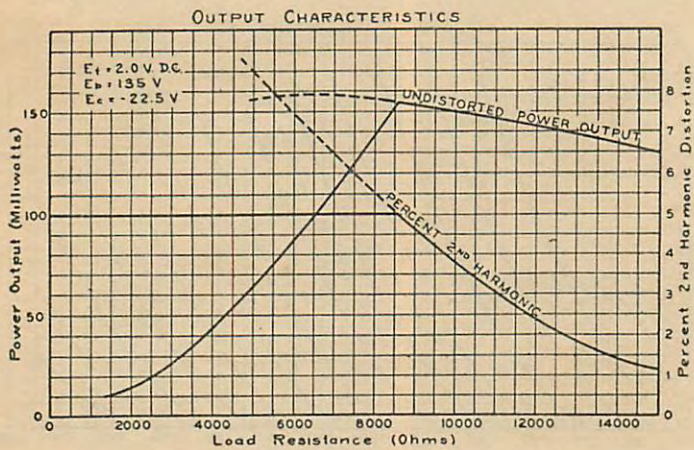

Fig. 11

CX-332 AVERAGE CHARACTERISTICS

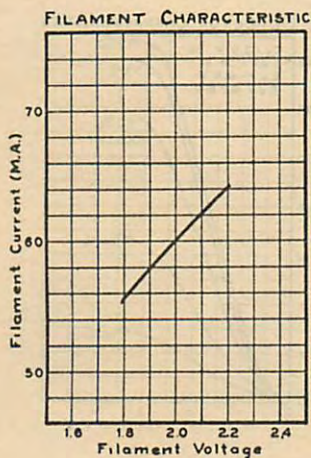

Fig. 12

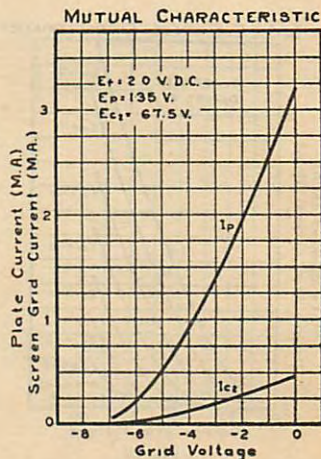

Fig. 13

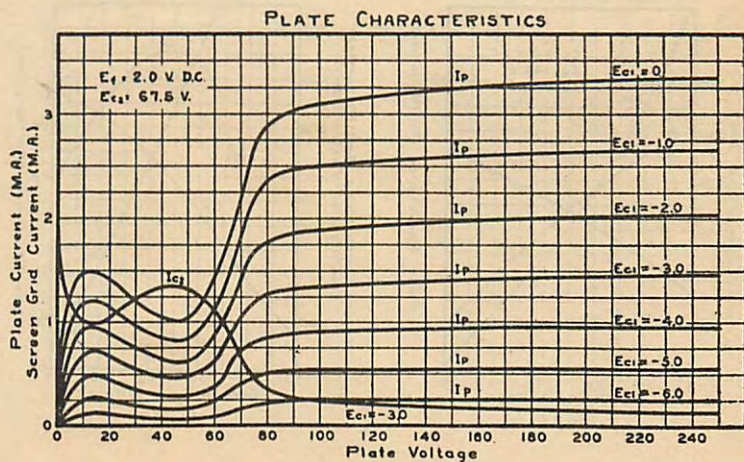

Fig. 14

CX-332

AVERAGE CHARACTERISTICS

INTER-ELECTRODE CHARACTERISTICS

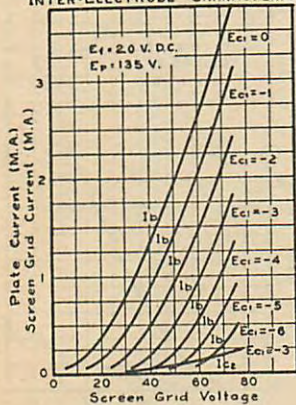

Fig. 15

DETECTOR CHARACTERISTICS

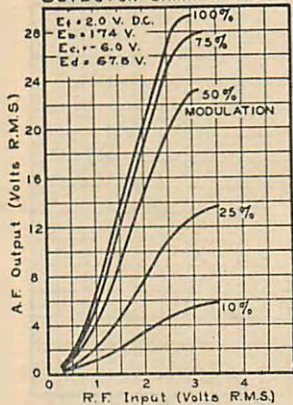

Fig. 16

DYNAMIC CHARACTERISTICS

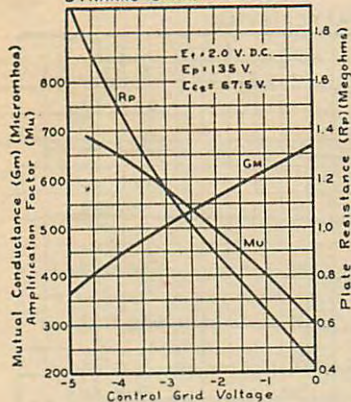

Fig. 17

DYNAMIC CHARACTERISTICS

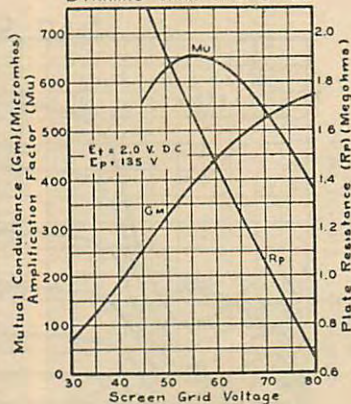
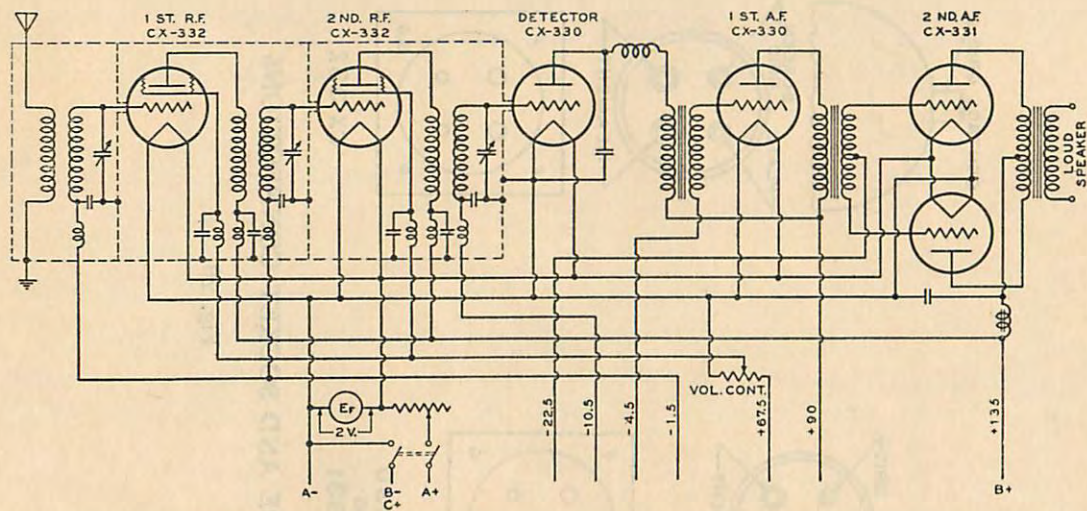
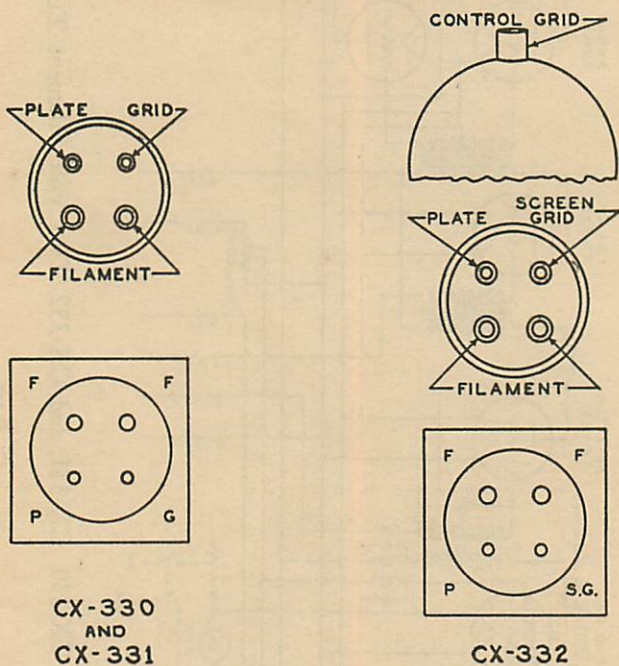

Fig. 18



Typical Circuit Using CX-330, CX-331, and CX-332 Two Volt Filament Tubes

Fig. 19



CX-330
AND
CX-331

CX-332

BASE AND SOCKET CONNECTIONS

Fig. 20

BULLETIN

POWER AMPLIFIER CX-345

This is a new tube which does not replace any other tube in the Cunningham line. CX-345 is not interchangeable with any Cunningham power amplifier.

Type CX-345
POWER AMPLIFIER



Type CX-345 is a new loud speaker power amplifier tube which will give power outputs between that obtained from the CX-371A and CX-350. It has been designed primarily for operation in A.C. sets and for this service has incorporated in it a very sturdy and long life filament. In general appearances it is similar to the CX-371A with a larger bulb.

This tube has been designed to operate at plate voltages of 180 to 250 volts, maximum. The grid bias at 180 volts is 33 volts for direct current operation and 34.5 volts for A.C. operation. At 250 volts the grid bias values are 48.5 volts and 50 volts for D.C. and A.C. operation, respectively.

In electrical characteristics it is similar to the CX-371A in that the amplification factor is 3.5, plate resistance is 1,750 ohms and mutual conductance is 2000 at a plate voltage of 250 volts. Under these conditions the average plate current is 34 milliamperes. The CX-345 is not interchangeable with CX-371A however, because the filament voltage is 2.5 volts. When inserted in a socket designed for CX-371A the tube

will either burn out or will burn out the filament winding of the power transformer. The filament is of the rugged coated type requiring 2.5 volts and 1.5 amperes. This filament has been especially designed to withstand the normal line voltage fluctuations and will give satisfactory life when operated between 5 percent above the normal rating of 2.5 volts and 5 percent below the normal rating.

BULB

The bulb provided for the CX-345 has a maximum diameter of $2 \frac{3}{16}$ " ; the maximum overall length from the end of the contact pins to the top of the bulb is $5 \frac{3}{8}$ ".

FILAMENT

The filament rating is 2.5 volts 1.5 amperes. The current required will normally be supplied by a 2.5 volt winding on the power transformer which should be so designed that the voltage across the filament does not at any time exceed 2.63 volts.

ELEMENTS

The plate and grid are similar to the plate and grid of the CX-371A. The collar construction used on the CX-350 is not used in this type since the maximum voltage applied to the plate does never exceed 250 volts; the maximum rating.

BASE

The standard large four prong base is employed.

MOUNTING

It is preferable to mount the tube in a vertical position and provision should be made for free circulation of air around the tube to prevent overheating. The plate of this tube should never show any visible color due to heating.

OPERATING CONDITIONS

Filament Volts	2.5	
Filament Amperes	1.5	
Plate Volts	180	250
Grid Voltage (A.C. Fila.)	-34.5	-50

AVERAGE TUBE CHARACTERISTICS

Plate Voltage	180	250
Grid Voltage (A.C. Fila.)	-34.5	-50
C Bias Resistor	1380	1470 ohms
Amplification Factor	3.5	3.5
Plate Resistance	1900	1750 ohms
Mutual Conductance	1850	2000 micromhos
Plate Current	27	34 milliamperes
Undistorted Output	780	1600 milliwatts

USE

The plate voltage on CX-345 must not exceed our maximum recommended value of 250 volts. When the power obtainable from one tube is insufficient for volume requirements, two tubes can be used in the conventional push-pull circuit. Operating push-pull with the maximum voltage of 250 volts the power output obtainable is 3200 milliwatts which is equivalent to the output obtained from one CX-350 operated at 400 volts. The distortion in the push-pull circuit with output load resistance of 8000 ohms is less than one-half of one percent.

The plate and grid voltage can be conveniently supplied from one CX-380 rectifier obtained at an input voltage of 350 volts per anode. Because of the high voltage and the high plate current an output coupling device either transformer or choke-condenser is recommended.

This tube is particularly free from gas and may be operated with the grid circuit resistance of one megohm or less. Because

of this condition the tube may be operated in a resistance coupled amplifier.

This tube must not be operated without a "C" voltage and precaution must be taken to prevent the loss of negative grid voltage which will cause the CX-345 to become overloaded and also the rectifier tubes supplying it.

As will be the condition in most cases, it is desirable that the bias required by the tube be supplied from the drop across the resistor in series with the minus "B" return, as shown in Fig. 7. It will be found that this connection compensates almost completely for the changes in plate voltage which may occur as a result of line voltage variations, as an increase in plate voltage causes a small increase in plate current which in turn raises the applied "C" bias sufficiently to compensate for the new value of plate voltage.

CURVES AND DATA

(Pages 73, 74 and 75)

The curve of Fig. 1 shows the average filament current of type CX-345.

Fig. 2 gives the average plate current over a range of plate voltages at zero grid bias.

Fig. 3 shows the amplification factor (μ), plate resistance (r_p) and mutual conductance (G_m) plotted in relation to grid voltage at plate voltage of 180 volts.

Fig. 4 shows the amplification factor (μ), plate resistance (r_p) and mutual conductance (G_m) plotted in relation to grid voltage at plate voltage of 250 volts.

Many times it is convenient to know the tube characteristics when the plate current only is known at an approximate value of plate voltage. For this reason we have included Fig. 5 which shows the various characteristics plotted against plate current. At the normal operating current there is little difference between the various values, but at the lower plate currents the variations are somewhat greater.

CX-345 AVERAGE CHARACTERISTICS

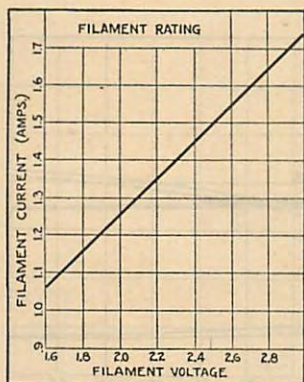

FIG. 1

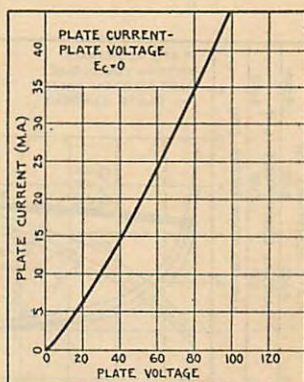

FIG. 2

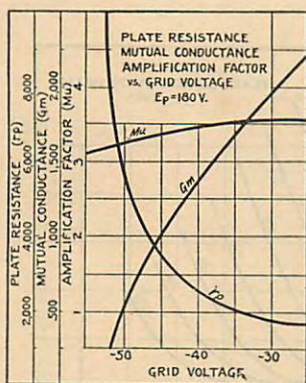

FIG. 3

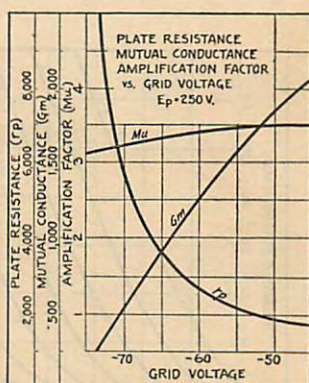

FIG. 4

CX-345 AVERAGE CHARACTERISTICS

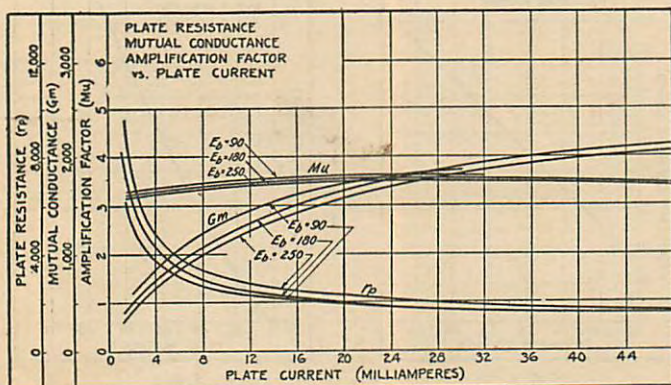

FIG. 5

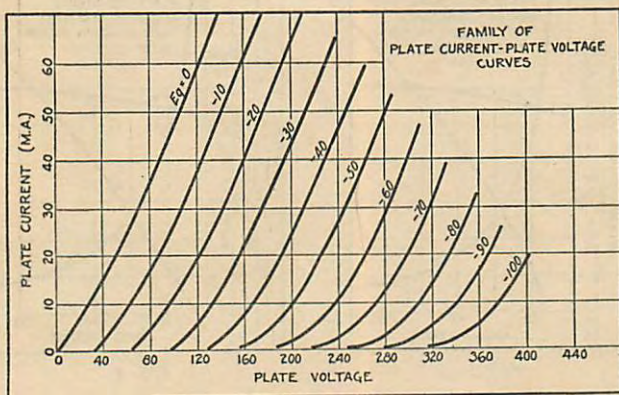

FIG. 6

Fig. 6 shows the family of plate current-plate voltage curves which are useful in calculating power output and determining the proper "C" battery voltages for definite plate currents. If A.C. filament operation is used, add 1.5 volts to the grid bias values given on the curves.

Fig. 7 shows a suitable circuit arrangement for type CX-345. With 250 volts plate voltage, R should be 1470 ohms. With 180 volts on the plate R should be 1380 ohms. This gives the proper "C" voltage at the average plate current.

Fig. 8 shows the typical output circuits which are recommended.

2ND AUDIO FREQUENCY AMPLIFYING STAGE

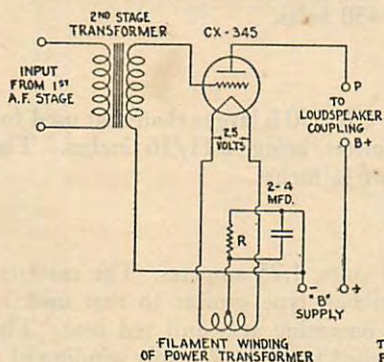

FIG. 7

LOUDSPEAKER COUPLING

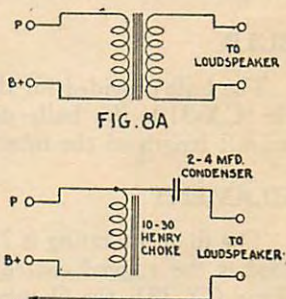

FIG. 8B

Cunningham RADIO TUBES

BULLETIN

Type CX-350 POWER AMPLIFIER



Type CX-350 is a heavy duty power amplifier tube. It is intended for use in installations where more undistorted power output is required than for average home use. In appearance it is somewhat larger than type CX-310.

This tube has been designed to operate at plate voltages from 250 to 450 volts maximum. Equipment designed to use the CX-350 must be capable of supplying the high plate current and the necessary grid bias, which is from -45 to -84 volts as shown in the tabulation.

Its performance characteristics are similar to the CX-371A and CX-345 having an amplification factor of 3.8, plate resistance of 1,800. ohms and mutual conductance of 2,100. at a plate voltage of 450 volts.

BULB

The bulb provided for the CX-350 is larger than that used for the CX-310, the bulb diameter being 2 11/16 inches. The overall length of the tube is 6 1/4 inches.

FILAMENT

The filament rating is 7.5 volts, 1.25 amperes. The material used is the rugged coated ribbon type similar to that used in Type CX-381, the filament operating at a dull red heat. The current required may be supplied from the 7.5 volt winding of a power transformer. The low operating temperature and the increased size of this type of filament results in minimum ripple voltage or "hum" when operated from such a source. The transformer should be so designed that the voltage across the filament does not exceed 7.9 volts (rated voltage plus 5%).

ELEMENTS

The plate of this tube is of special construction to permit ample radiation. It is supported by a collar on the stem so that a maximum B voltage of 450 volts can be used.

BASE

The standard large four prong base is employed.

MOUNTING

It is preferable to mount the tube in a vertical position and provision should be made for circulation of air around the tube to prevent overheating. An indication of overheating is obtained from the appearance of the tube, the plates of which should never exceed a barely visible red at any spot on either side of the plate.

OPERATING CONDITIONS

Filament Volts	7.5
Filament Amperes	1.25
Plate Volts (Max.)	450.
Plate Current (Max.)	55 m.a.
Grid Volts	See Table

AVERAGE TUBE CHARACTERISTICS

Plate Volts	Neg. Grid Bias Volts	Mu	Plate Resist.	Mutual Conduct.	Plate Current	Bias Resistor Ohms	Undistorted Power Output Milliwatts
250	-45	3.8	2100	1800	28	1600	1000
350	-63	3.8	1900	2000	45	1400	2400
400	-70	3.8	1800	2100	55	1300	3400
450	-84	3.8	1800	2100	55	1550	4600

USE

Maximum life is obtained from the CX-350 when the tube is used at conservative plate voltages. Voltages between 250 and 400 volts are recommended, and the voltage must not exceed a maximum value of 450 volts. When the tube is used in place of the CX-310 (as noted below circuit changes should be made before the tube is substituted for this type) the plate voltage need not exceed 300 volts if the power output obtainable from the CX-310 operated at 425 volts has proven adequate. Thus for equivalent power output a considerably lower plate voltage may be used with the CX-350, the total required for the tube and grid biasing voltage being 300+54, or 354 volts as compared with 425+35 or 460 volts for the CX-310.

The higher current required by the CX-350 can be conveniently supplied by a CX-381 rectifier (or by two such tubes

with full wave connection). The average plate current required ranges from 28 m.a. at 250 volts to 55 m.a. at 400 volts. Since the CX-381 is rated at 85 m.a. output (see Fig. 4) sufficient margin is available so that the same rectifier used for the CX-350 may also supply the plate current required by the remaining tubes in the receiver.

The CX-350 is of the low mu type, the amplification factor being 3.8. The normal plate current is relatively high, and will reach values which may result in damage to the tube unless certain precautions are taken in using this model, as follows:

1. The grid bias must be applied at all times while the tube is in operation. If the grid circuit is opened the plate current will increase to a high value, overloading both the power tube and particularly the rectifier tube—if the current is supplied from such source—and is very apt to cause burnout of the filament in the latter. It is very desirable to protect both by a fuse, or similar device, operating at about .1 ampere, and which should be placed in the rectifier circuit between the rectifier and the filter. It is possible to use the .1 ampere 6 volt dial lamp, type T3, which, although not designed for high voltage, will usually break the circuit.

2. The coated filament is not affected by traces of gas, and a slight blue glow will not impair or affect the performance of the tube provided the resistance in the grid circuit is kept low, preferably not over 10,000 ohms, to avoid a decrease in bias which may otherwise result from the flow of gas current to the grid. The tube is not intended for use in resistance coupled amplifiers.

It is desirable that the bias required by the tube be supplied from the drop across a resistor in series with the -B return, as shown in Fig. 5. It will be found that this connection compensates almost completely for changes in plate voltage which may occur as a result of line voltage variations, as an increase in plate voltage causes a small increase in plate current which in turn raises the applied "C" bias sufficiently to compensate for the new value of plate voltage, thus maintaining the proper operating condition at all times. If a decrease in voltage occurs, the reverse action takes place. This desirable operating condition is sacrificed if a fixed "C" bias derived from a battery or other source is provided, as in such cases a decrease in plate

voltage will cause a large decrease in plate current which will greatly reduce the power output obtainable from the tube, while an increase in plate voltage will overload the tube.

A low resistance output choke with a condenser, or a transformer capable of handling the heavy plate current of the CX-350 without saturation of the core, or overheating of the windings must be provided for this tube to prevent excessive voltage drop in the plate circuit and to protect the loud speaker windings.

CURVES AND DATA—(Page 80)

The curves, Fig. 1, show the average filament current and the filament emission of type CX-350.

Fig. 2 gives the average plate current over a range of plate voltages, with no applied grid bias. In taking this data, the grid return was connected to the midpoint of the filament, and for this reason the plate current does not reach zero until a negative plate voltage is applied.

Fig. 3 shows the amplification factor (μ), plate resistance (r_p), and mutual conductance (G_m) plotted as a function of plate current. This method of showing tube characteristics is convenient, since a single measurement, that of plate current, suffices to determine the operating point.

Fig. 4, furnished for convenient reference, shows the voltage and current output of the CX-381 at various loads. The full lines show the output of a single CX-381 with the usual filter arrangement, while the dotted lines show the output obtained from two CX-381 tubes in a full wave rectifier, using a filter in which the first filter condenser is omitted. The IR drop in the filter must be taken into consideration before this data is complete. As soon as the resistance of the filter chokes is measured the output voltage obtainable can be computed.

Fig. 5 shows circuit arrangements suitable for the CX-350. When substitution of this type for type CX-310 is desired the necessary circuit changes include a change in the resistance R to the proper value as indicated below, and substitution of an output device having higher current carrying capacity if that provided for the CX-310 is inadequate.

CX-350 AVERAGE CHARACTERISTICS

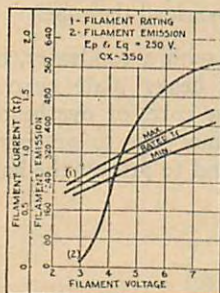

FIGURE 1

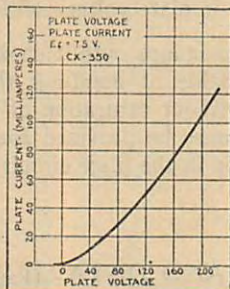

FIGURE 2

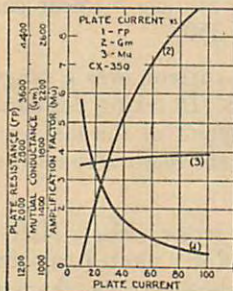

FIGURE 3

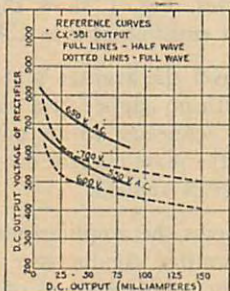

FIGURE 4

AUDIO FREQUENCY POWER STAGE

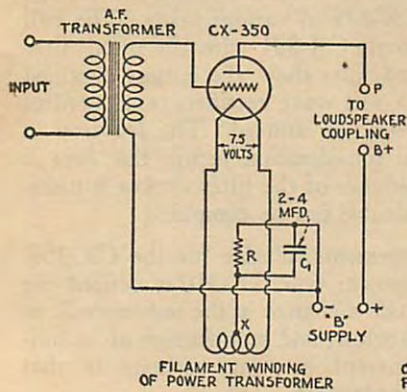

FIG. 5

LOUDSPEAKER COUPLING

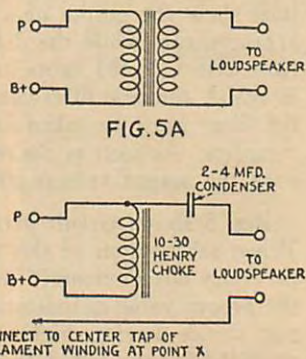

FIG. 5B

Cunningham RADIO TUBES

CX-374, C-376 and C-386 VOLTAGE REGULATOR TUBES

The CX-374, C-376 and C-386 are known as Voltage Regulator tubes. This group comprises two distinct types, one being an output voltage regulator and the other a line voltage regulator.

CX-374 OUTPUT VOLTAGE REGULATOR



The CX-374 is a special "glow" type voltage regulator designed for service in "B" supply units where great flexibility in output is required or where the A.C. line voltage varies over rather wide limits. This tube accomplishes voltage regulation from its characteristic that on any current flow from 10 to 50 milliamperes the tube develops a constant voltage averaging 90 volts. It consists of two elements (an anode and a cathode) in a gas-filled space and shows a pronounced glow when in operation.

Circuit Requirements

This tube cannot be used without a series resistance to limit the maximum current to 50 milliamperes. The application of the tube to a typical "B" supply unit is shown in Fig. 1. If the tube connections are reversed a bright glow will occur at the small terminal, and the connections should be corrected. Proper results will not be obtained unless connections are made as indicated in the diagram. The terminals which would normally be "+F" and "plate" are connected together in the base of the tube and this short circuited connections may be used as a line switch in the transformer primary. With this connection, the eliminator cannot be turned on until the CX-374 tube is inserted in the socket nor can the tubes be interchanged in such a way as to damage either the equipment or tubes themselves. If a rectifier or power tube is inserted in the socket intended for the CX-374, the transformer primary will remain open and no power will flow to the equipment.

Two CX-374 tubes may be placed in series to obtain 180 volts, a center tap between the two tubes then providing 90 volts.

RATING

Rated Voltage	90 volts D.C.
Starting Voltage	125 volts D.C.
D.C. Current	10-50 milliamperes

DIMENSIONS

Maximum Overall Length	5 $\frac{5}{8}$ "
Maximum Diameter	2 $\frac{3}{16}$ "
Base	Large CX

C-376 and C-386

LINE VOLTAGE REGULATOR



The C-376 and C-386 are "ballast" tubes designed to regulate the input voltage to the primary of power transformers. Either of these tubes when placed in series with a transformer primary of such design that 50 volts is applied to the tube, will maintain a constant current in the circuit. In this way a constant voltage is maintained on the load and the tube serves as a voltage regulator.

Circuit Recommendations

It takes several minutes for these tubes to heat up, the voltage drop increasing rapidly for the first three minutes and then slowly up to about ten minutes, by which time the tube has reached its final temperature. During this interval the voltage on the load will be slightly high, but will not exceed safe values, and thereafter the regulator tube will maintain the voltage practically constant.

As a matter of safety, these tubes should be housed in a metal covering that has proper ventilation.

The C-376 will regulate the primary transformer voltage on frequencies from 25 cycles to 60 cycles provided the transformer

has been designed for the operating frequency and under load fulfills the above condition. Equipment designed for 60 cycles with the C-376 may be used on 40 cycle sources with the C-386.

RATING

	C-376	C-386
Operating Current	1.7	2.05 amperes
Voltage Range	40-60	40-60 volts

DIMENSIONS

Maximum Overall Length	8"	8"
Maximum Diameter	$2\frac{1}{16}$ "	$2\frac{1}{16}$ "
Base	Mogul	Mogul

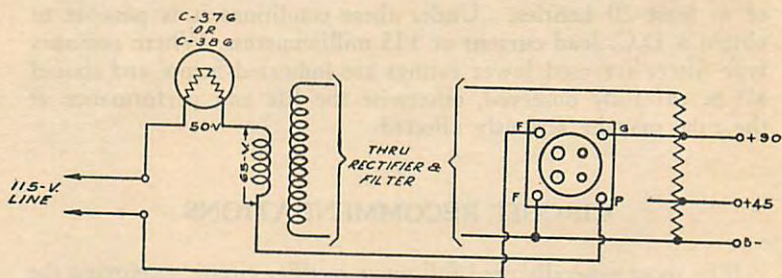

FIG. 1

Cunningham RADIO TUBES

BULLETIN

Type CX-380

FULL WAVE RECTIFIER

The CX-380 is a full-wave rectifying tube intended for use in power supply devices that operate from an alternating current supply.



FILAMENT

The filament of this tube is of the oxide coated type and is designed to operate at 5 volts. The filament current is supplied from one of the windings of a power transformer, the leads to which should be of high current carrying capacity.

PLATE

There are two plates in the CX-380, both designed to operate at voltages *no higher than* 550 volts A.C. each, which value is permissible only with filter circuits having an input choke of at least 20 henries. Under these conditions it is possible to obtain a D.C. load current of 135 milliamperes. Where ordinary type filters are used lower ratings are indicated below and should all be carefully observed, otherwise the life and performance of the tube may be seriously affected.

CIRCUIT RECOMMENDATIONS

The most generally used full-wave rectifier circuit employing the CX-380 is shown in fig. 2A. The filter used may be either of the condenser or choke input types. With condenser input (as shown in fig. 2B) care must be taken that this input condenser should have a rating sufficiently high to withstand the instantaneous peak value of the A.C. input voltage.

In the case of the choke input method (fig. 2C) where the input condenser of fig. 2B is omitted, there will be a somewhat lower available D.C. output voltage for a given A.C. plate voltage than with the condenser input method. However, improved regulation with lower peak current will be obtained. When using 550 volts

per plate, this type of filter is necessary as mentioned before and an input choke of at least 20 henries must be used. If desired, a condenser of not more than 0.1 mfd. may be used across the input.

OPERATING CONDITIONS

Filament Voltage	5.0 volts	
Filament Current	2.0 amperes	
A.C. Voltage per Plate with		
135 m.a. D.C. Output Current (max.)	550 volts (R.M.S.)	—permissible only with filter circuits having an input choke of at least 20 henries. If desired, a condenser of not more than 0.1 mfd. may be used across the input of the filter.
125 m.a. D.C. Output Current (max.)	350 volts (R.M.S.)	
110 m.a. D.C. Output Current (max.)	400 volts (R.M.S.)	

DIMENSIONS

Maximum Overall Length	5 5/8"
Maximum Overall Diameter	2 3/16"

BASE

Standard Large CX

AVERAGE CHARACTERISTIC CURVES

(Page 86)

Filament Characteristic—Fig. 1 shows the change of filament current with various filament voltages.

Output Characteristics—Fig. 3 shows the relation of load current to the rectified voltage at various plate voltages when using a condenser input filter.

Fig. 4 shows the relation of load current to the rectified voltage when using a choke input filter.

CX-380

AVERAGE CHARACTERISTICS

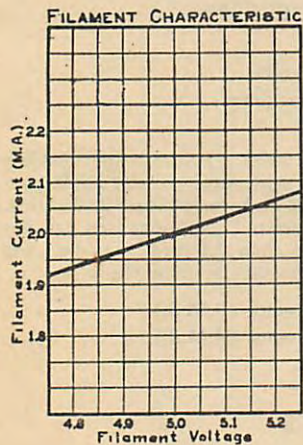

Fig. 1

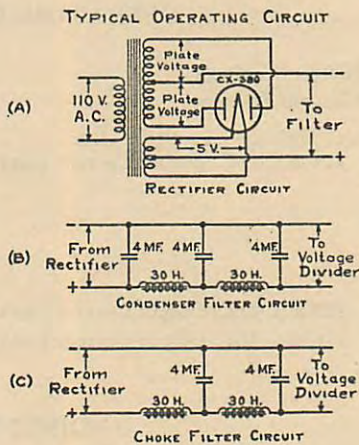

FIG. 2

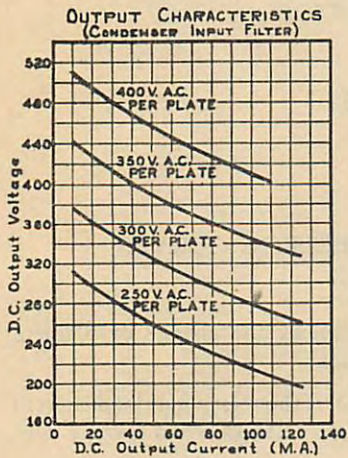

FIG. 3

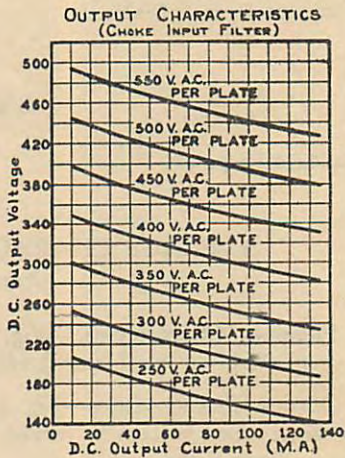
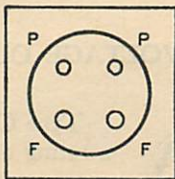
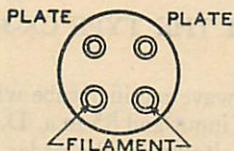

FIG. 4



CX-380

BASE AND SOCKET CONNECTIONS

Cunningham RADIO TUBES

BULLETIN

HIGH VOLTAGE OUTPUT WITH THE TYPE CX-381 TUBE



Type CX-381 is a half-wave rectifier tube with a rating of 700 volts A.C. input and 85 m.a. D.C. output permitting D.C. voltages on the order of 600 volts to be obtained from a single wave rectifier, and of 700 volts with a full wave connection. When higher voltages are required it is possible to use a single or full wave voltage doubling arrangement by which voltages of 1000 to 1500 volts may be obtained (using low transformer voltages), two to four CX-381 tubes being required.

NORMAL SERVICE

Typical connections and output voltage secured from the CX-381 in a half wave rectifier circuit are shown in Fig. 1, while Fig. 2 shows similar data for two CX-381 tubes used in a full wave circuit. When an output voltage under 500 volts is required the first filter condenser should be omitted. The effect of this connection is to greatly reduce the peak current supplied by the CX-381 tubes, which will run cooler and give much better life service under such conditions. The regulation is also much improved, as may be seen by comparing the output voltage curves.

This latter system of filtering was tried at station 2AQO, in place of a single section filter, with improved results when supplying a Hartley oscillator and especially for phone modulation. The filtering action was better than necessary for crystal controlled operation, some A.C. modulation being found preferable. The input choke in these tests was a 7 Henry inductor, the self-inductance being measured with full load current of 85 m.a. flowing.

HIGHER VOLTAGES

A familiar type of voltage doubling connection was tested (Fig. 3). The voltage regulation was rather poor, as indicated, but for low currents the small amount of apparatus required makes it convenient. The regulation can be improved by using two CX-381 tubes in parallel on each side as indicated by the

dotted lines. The voltage increases rather rapidly below a load of 20 m.a., and to prevent it from rising a fixed load (r) is indicated in the diagram. This may be a 100,000 ohm resistor capable of carrying 20 m.a. A milliammeter in series with this resistor is indicated (M.A.), and will give an indication of the output voltage. The scale reading with the resistor specified becomes 100 volts per milliampere; thus a full scale reading of 200 milliamperes indicates an output voltage of 2000 volts.

Much improved results were obtained with the full wave voltage doubling circuit shown in Fig. 4. The adjacent curves show the very high output voltage obtainable with this circuit, and the excellent regulation secured. The high voltage transformer may be a 1400 volt winding center tapped, or two similar 700 volt transformers connected in series. Regulation curves are shown for transformer voltages of 1000 and 1400 volts. The current output should not exceed 170 m.a. Three separate filament transformers insulated for the full output voltage are required.

When tested at Station 2ABQ this latter arrangement, with a 10 Henry choke, gave slightly better results than the equipment formerly used, a 3000 volt transformer center tapped two 1500 volt rectifiers and a 50 Henry choke. The transformer used was a 1200 volt unit, center tapped. The CX-381 tubes, supplying 100 m.a. ran quite cool, the output being well below rated maximum.

The filter condensers, C1, must be capable of withstanding one-half the load voltage as the normal working voltage. A condenser larger than 4 m.f. should not be used unless it is possible to close the filament circuit of the rectifier tubes before the high voltage is applied. The initial charging surge may overheat the tubes and cause an arc if the filament is allowed to come up to temperature with the high voltage turned on.

FILAMENT

The filament used in type CX-381 is of the rugged coated type. With this filament the difficulties in handling the shipping are overcome, as severe mechanical shocks cannot break the filament. The filament should be operated at, or slightly below, the rated voltage of 7.5 volts, and the voltage across the filament should never exceed 7.9 (rated voltage \pm 5%).

The main precaution to be observed in operating the CX-381 tubes is that of avoiding an overload with respect to plate current. The shorting of the rectifier output, such as may occasionally occur due to the failure of some part of the apparatus (as by the breakdown of a filter condenser) will overload the filament and result in filament failure, unless the current is turned off promptly. An indicating lamp may be placed in the circuit in series with each plate lead adjacent to the plate; if a .15 ampere 6 volt dial lamp is used in this position it will glow at normal brilliancy when the full rated current of 85 m.a. is flowing through each tube (170 m.a. from a full wave rectifier). Excessive brilliancy of this lamp will immediately indicate an overload on the tube, which can be corrected before damage results.

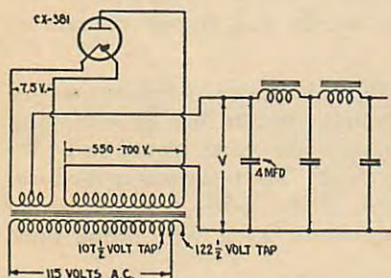

FIG. 1

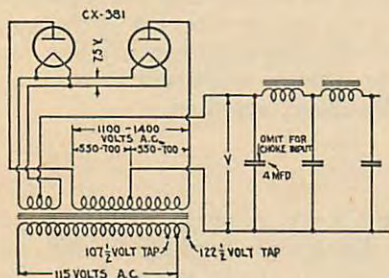
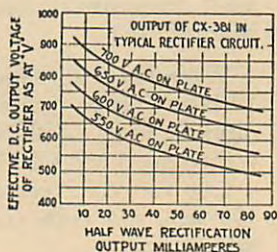
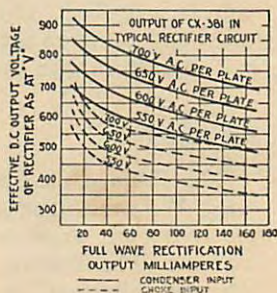

FIG. 2



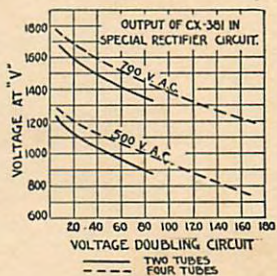
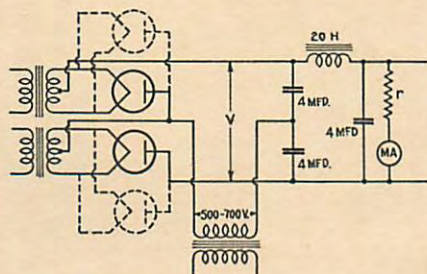

FIG. 3

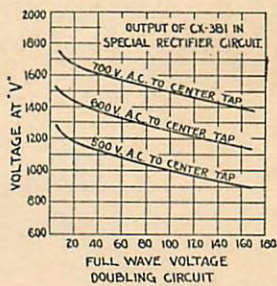
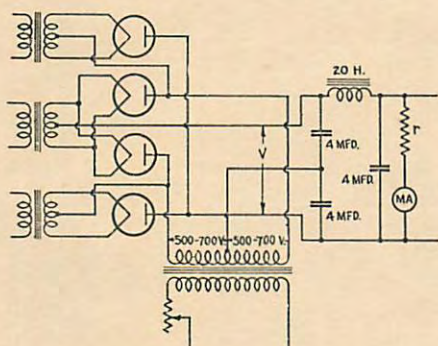
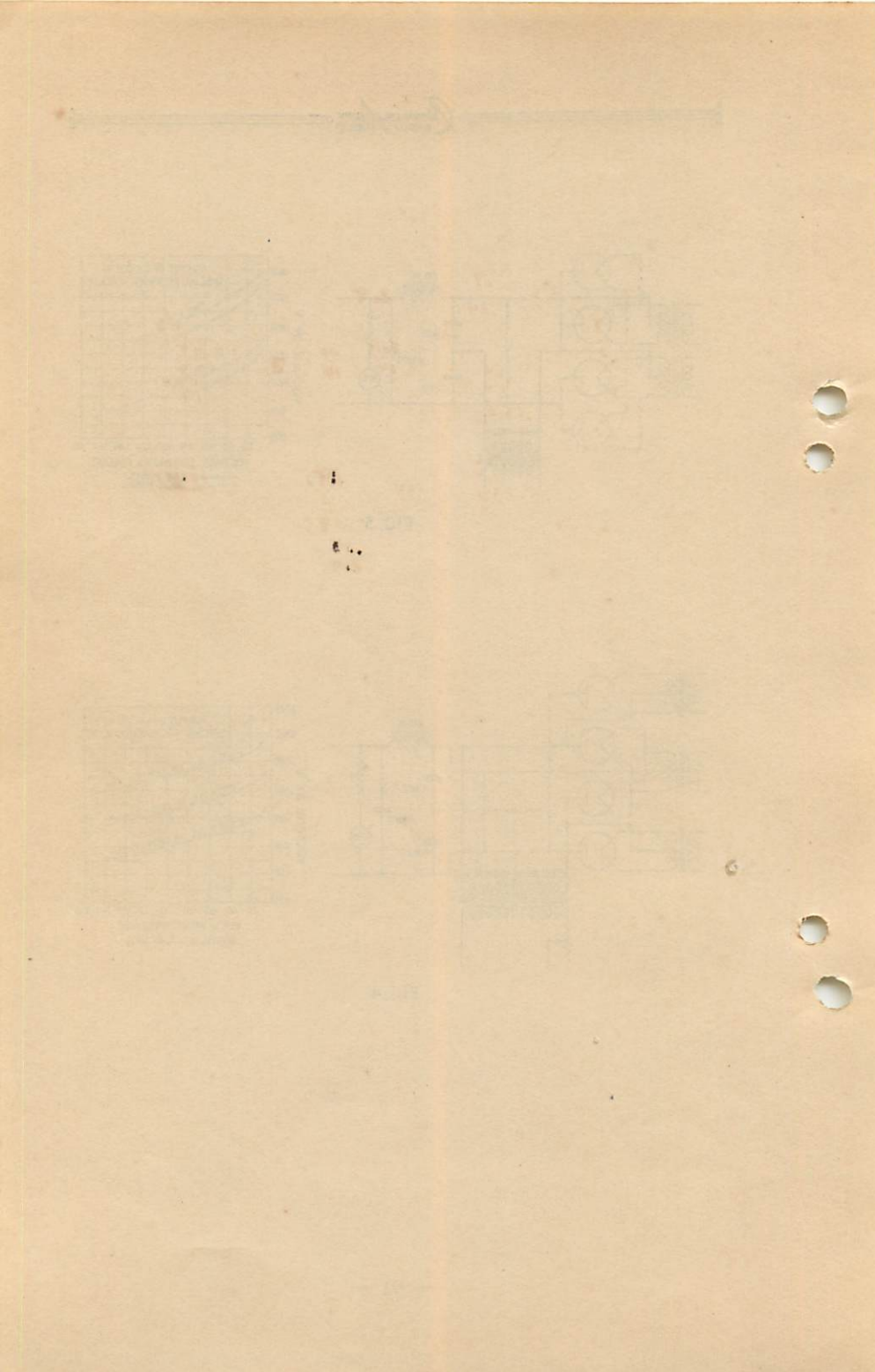

FIG. 4



MEMORANDUM

$$R = \frac{.7}{.24} = 2.8$$

$$\frac{.9}{.24}$$

$$\begin{array}{r} .64 \\ \underline{4} \\ .256 \end{array}$$

$$\frac{4 \cdot 10}{14} = \frac{40}{14} = 2$$

$$14 \overline{) 40} \begin{array}{l} 28 \\ \underline{28} \\ 120 \\ \underline{112} \\ 8 \end{array}$$

$$\begin{array}{r} .56 \\ \underline{4} \\ .224 \\ \underline{3} \end{array}$$

$$.22 \quad \begin{array}{r} .195 \\ \underline{3} \\ .585 \\ \underline{.73} \\ -2.4 \end{array}$$

10.60

MEMORANDUM

Thoriated Tungsten	Coated Fil
00A	1A4 81
01A	1A6 82
10	1B4 112
20	1B5
40	1C6
	2A6
	5W4
	573
	6A4
	11
	12
	19
	22
	26
	30
	31
	32
	33
	34
	45
	46
	47
	49
	58
	71-94-
	80

MEMORANDUM

00A has .100 μ a grid circuit for
zero bias.



MEMORANDUM

MEMORANDUM

1. $I_f, I_b + I_c \quad \text{vs} \quad E_f$
 $I_c \quad \text{vs} \quad E_g$
2. $I_p \quad \text{vs} \quad E_p$ Triode
 $I_p \quad \text{vs} \quad E_g$
3. $I_p \quad \text{vs} \quad E_p$ } Sq.
 $I_s \quad \text{vs} \quad E_s$
4. $I_p \quad \text{vs} \quad E_p$ } Pentode.
 $I_s \quad \text{vs} \quad E_s$
5. $R_o, gm \quad 37, 75.$
6. $gm, R_o, \quad 36,$
7. $W_f \sim 31, 37, 04-A, 00.$
8. $S_m - 36 \quad Res.$
9. $S_m - 37 \quad \text{Choke with v.t. um.}$
10. Rectifier - Choke + Cond.
11. Oscillator
12. Amplifier - A, B, C.
13. Modulator.
- 14.

MEMORANDUM

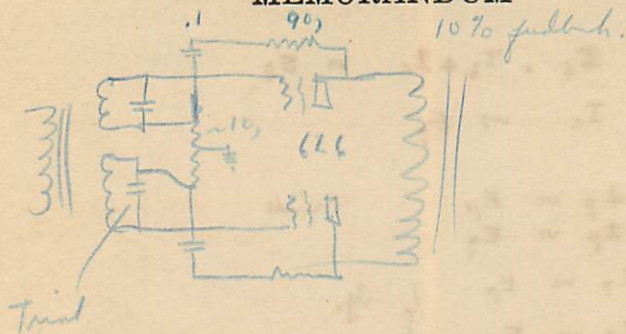

CX-112—AN OLD MODEL POWER TUBE

According to our records, CX-112 tubes illustrated below have not been available to the trade since January 1928, indicating that they have had time to give more than normal service in the hands of the consumer.

You render your customers a real service when you sell them new and more efficient tubes to take the place of these old ones.

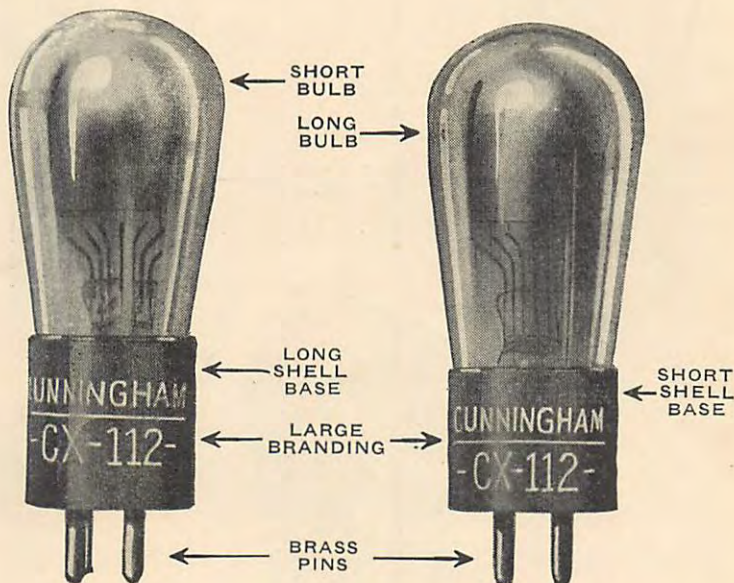

Notice that this old type is branded
CX-112, NOT CX-112A

CX-112 Tubes described above will not be replaced at Cunningham Service Stations.

C-301-A—AN OLD TIMER

According to our records, tubes shown below have not been available to the trade since January, 1926, indicating that they have had time to give more than normal service in the hands of the consumer.

Do you deprive yourself of legitimate sales by handling merchandise for adjustment which has seen as much service as these "old-timers"?

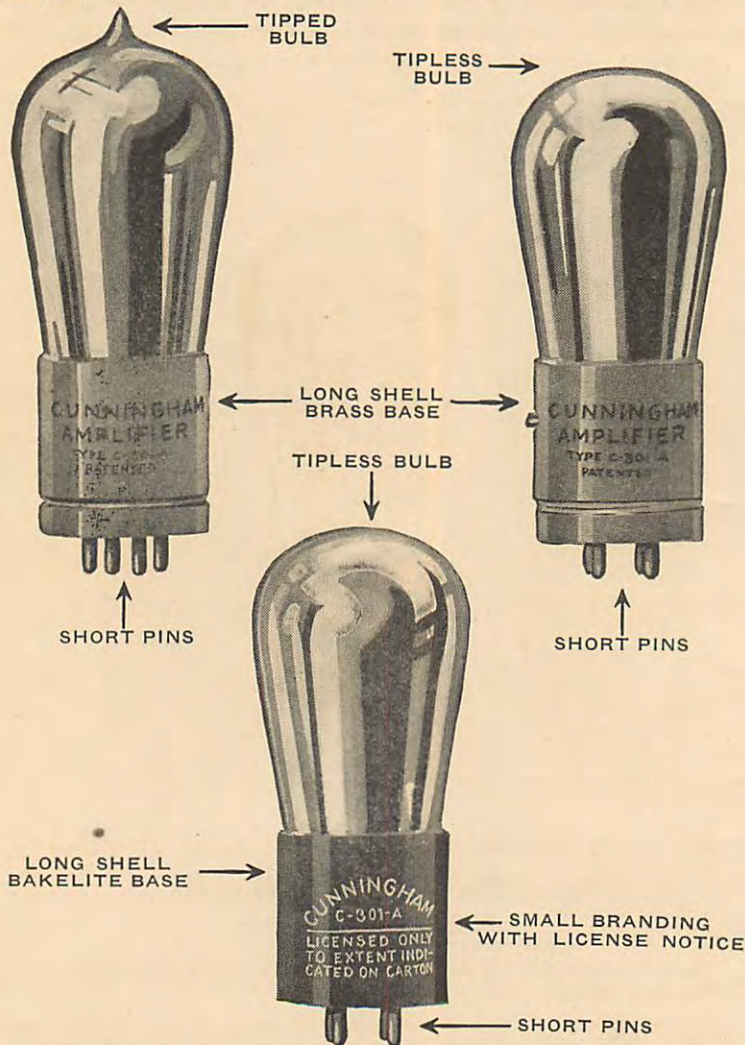

C-301-A Tubes as described above will not be replaced at Cunningham Service Stations.

CX-326—FIRST PRODUCTION

According to our records, the first production CX-326 tubes illustrated below have not been available to the trade for a long time, indicating that any in use today have given far more than normal service in the hands of the consumer.

Ask your customers, who bring in these early models, how long they have been in service.



The large lettering used in the branding identifies this early production of CX-326.

The old model CX-326 described above will not be replaced at Cunningham Service Stations.

This should not be construed to indicate that tubes of other types which show normal wear or mishandling will be considered for replacement.

CX-301A—EARLY MODELS

According to our records, the early model CX-301A tubes illustrated below have not been available to the trade for a long time, indicating that any in use today have given far more than normal service in the hands of the consumer.

Your customers are ready to buy new tubes when their old ones have given long service.

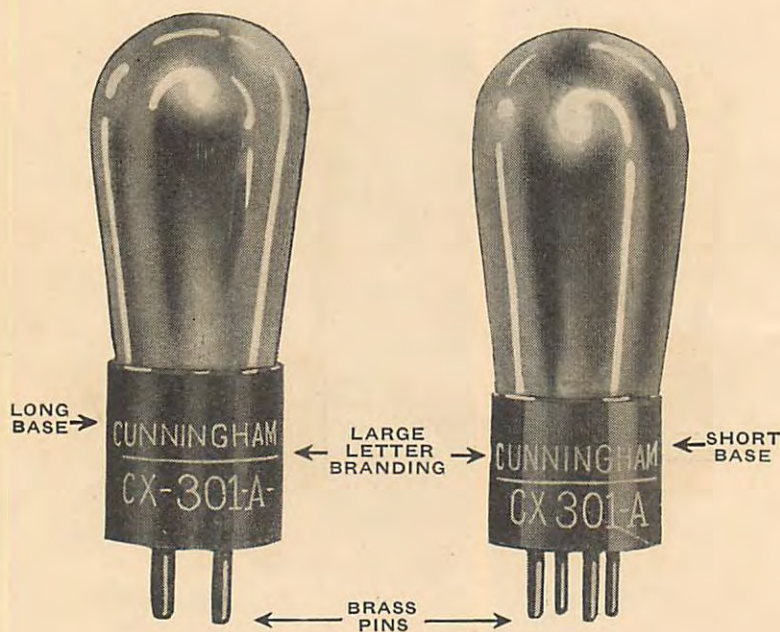

Brass Pins and the Branding in Large Letters Identify These As Old Models

Old Model CX-301A Tubes described above will not be replaced at Cunningham Service Stations.

This should not be construed to indicate that tubes of other types which show normal wear or mishandling will be considered for replacement.

CX-371—AN EARLY MODEL POWER TUBE

According to our records, CX-371 tubes illustrated below have not been available to the trade for a long time, indicating that any in use today have given far more than normal service in the hands of the consumer.

Will you take money out of your cash register by considering this old type for replacement?

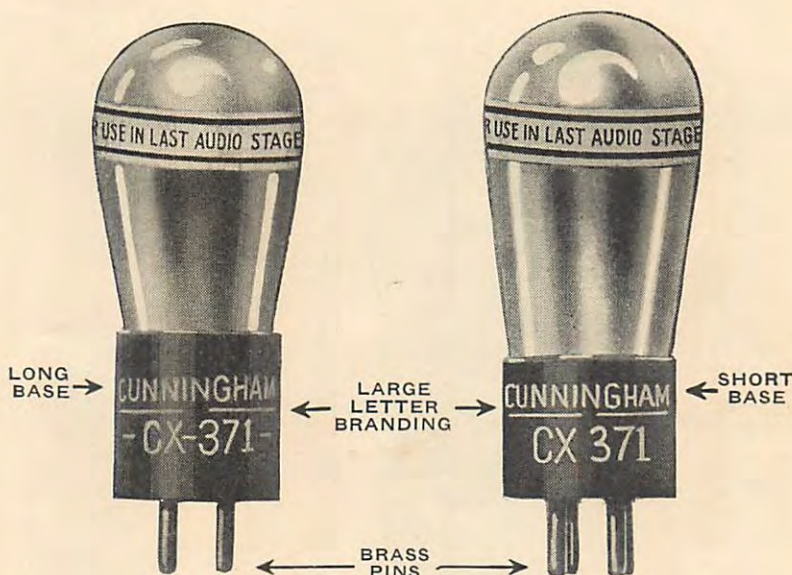

This old type is branded CX-371, NOT CX-371A

Brass Pins and the Branding CX-371 in Large Letters
Identify These Old Timers

CX-371 Tubes described above will not be replaced at Cunningham Service Stations.

This should not be construed to indicate that tubes of other types which show normal wear or mishandling will be considered for replacement.

C-327—EARLIEST MODEL

According to our records, the first production C-327 tubes illustrated below have not been available to the trade for a long time, indicating that any in use today have given far more than normal service in the hands of the consumer,

Be fair to your customers and yourself when they bring you these old tubes.



The absence of a mica spacer and the use of the glass bead support identify this earliest model of C-327.

The old model C-327 described above will not be replaced at Cunningham Service Stations.

This should not be construed to indicate that tubes of other types which show normal wear or mishandling will be considered for replacement.

CX-313—OBSOLETE TYPE FULL WAVE RECTIFIER

According to our records, CX-313 tubes illustrated below have not been available to the trade for a long time, indicating that any in use today have given far more than normal service in the hands of the consumer.

When your customers bring in this old type, they are ready to buy a CX-380—the new and more efficient type which supercedes CX-313.

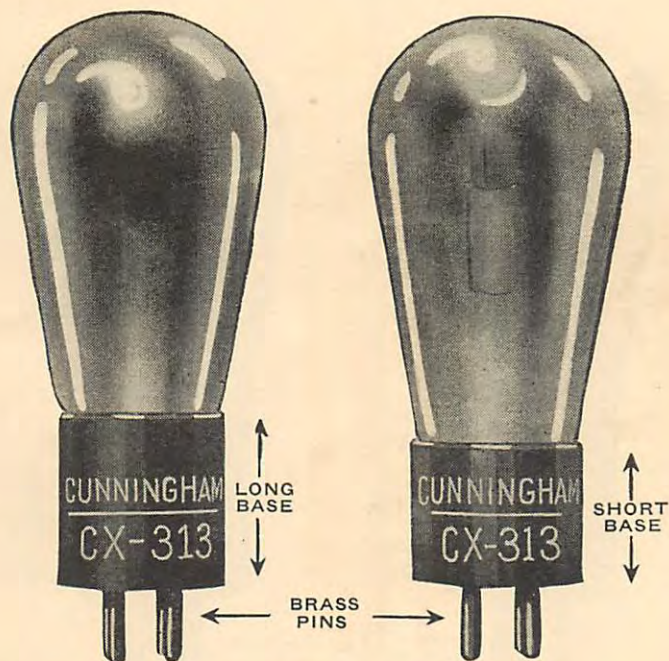

**Brass pins and the branding CX-313
identify these as obsolete models.**

CX-313 Tubes described above will not be replaced at Cunningham Service Stations.

This should not be construed to indicate that tubes of other types which show normal wear or mishandling will be considered for replacement.

CX-316B—OBSOLETE TYPE HALF WAVE RECTIFIER

According to our records, CX-316B tubes illustrated below have not been available to the trade for a long time, indicating that any in use today have given far more than normal service in the hands of the consumer.

You render your customers a real service when they bring in this old type, by supplying them with CX-381, the new and more efficient type which is interchangeable with CX-316B.

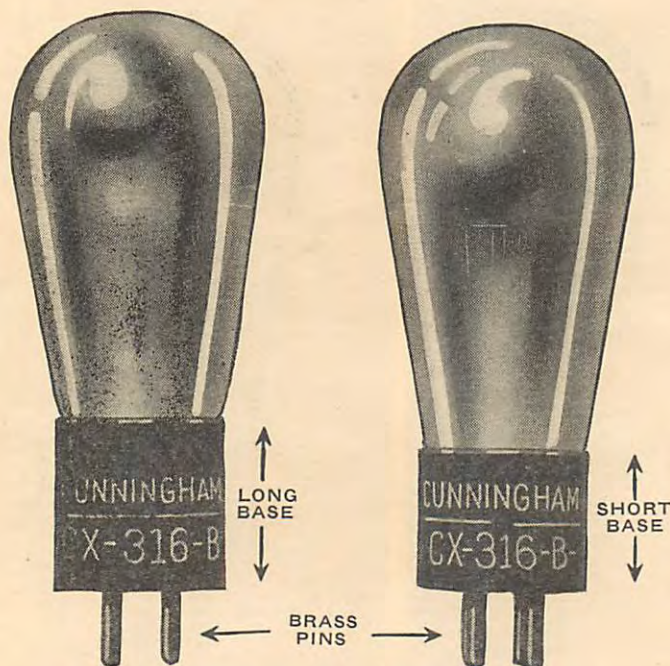

**Brass pins and the branding CX-316-B
identify these obsolete models.**

CX-316B Tubes described above will not be replaced at Cunningham Service Stations.

This should not be construed to indicate that tubes of other types which show normal wear or mishandling will be considered for replacement.

EARLY PRODUCTION CX-380

According to our records, the early model CX-380 tube illustrated below has not been available to the trade for a long time, indicating that any in use today have given far more than normal service in the hands of the consumer.

Your customers are ready to buy new tubes when their old ones have given long service.

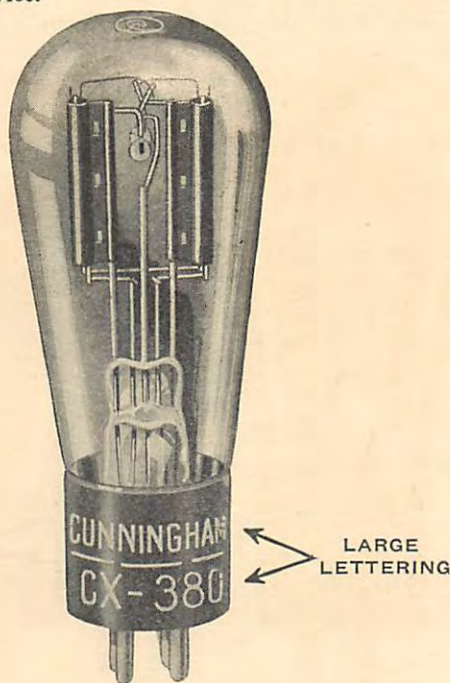

The branding in large letters identifies the early models of CX-380.

Old Model CX-380 Tubes described above will not be replaced at Cunningham Service Stations.

This should not be construed to indicate that tubes of other types which show normal wear or mishandling will be considered for replacement.

OBSOLETE MODEL OF CX-301A

According to our records, the early model CX-301A tube illustrated below has not been available to the trade for a long time, indicating that any in use today have given far more than normal service in the hands of the consumer.

When your customers bring in these old timers, ask them how long they have been in use. Call their attention to the long service these have given and you will find them ready to buy new ones for renewal.



The branding in large letters identifies this Old Model of CX-301A.

Old Model CX-301A Tubes described above will not be replaced at Cunningham Service Stations.

This should not be construed to indicate that tubes of other types which show normal wear or mishandling will be considered for replacement.

CX-299—FIRST PRODUCTION

According to our records, the first production CX-299 tube illustrated below has not been available to the trade for a long time, indicating that any in use today have given far more than normal service in the hands of the consumer.

Ask your customers, who bring in these early models, how long they have been in use. They are ready to buy new ones when their old tubes have given long service.



BRASS PINS

**Brass Pins identify this very early production
of CX-299.**

Old Model CX-299 Tubes described above will not be replaced at Cunningham Service Stations.

This should not be construed to indicate that tubes of other types which show normal wear or mishandling will be considered for replacement.

CX-322—EARLIEST MODEL

According to our records, the early model CX-322 tube illustrated below has not been available to the trade for a long time, indicating that any in use today have given far more than normal service in the hands of the consumer.

Do you deprive yourself of legitimate sales by handling merchandise for replacement which has seen as much service as this old timer.



Brass Pins identify this earliest model CX-322.

Old Model CX-322 Tubes described above will not be replaced at Cunningham Service Stations.

This should not be construed to indicate that tubes of other types which show normal wear or mishandling will be considered for replacement.

EARLY PRODUCTION CX-112A

According to our records, the early production CX-112A tube illustrated below has not been available to the trade for a long time, indicating that any in use today have given far more than normal service in the hands of the consumer.

Your customers are ready to buy new tubes when their old ones have given long service.

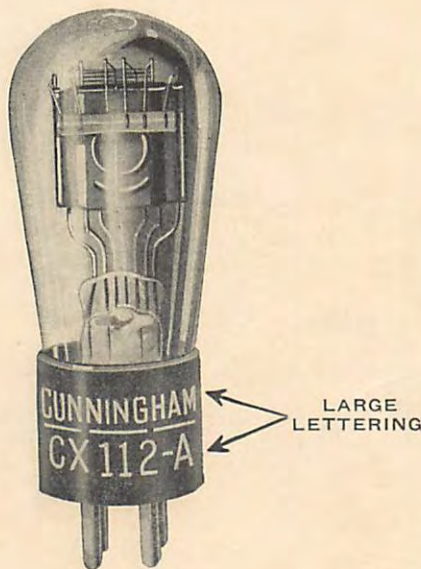

The branding in large letters identifies this early production CX-112A.

Old Model CX-112A Tubes described above will not be replaced at Cunningham Service Stations.

This should not be construed to indicate that tubes of other types which show normal wear or mishandling will be considered for replacement.

EARLY PRODUCTION CX-371A

According to our records, the early production CX-371A tube illustrated below has not been available to the trade for a long time, indicating that any in use today have given far more than normal service in the hands of the consumer.

Will you take money out of your cash register by considering this old type for replacement?



The branding in large letters identifies this early production of CX-371A.

CX-371A Tubes described above will not be replaced at Cunningham Service Stations.

This should not be construed to indicate that tubes of other types which show normal wear or mishandling will be considered for replacement.